

MODERN ROBOTICS

MECHANICS, PLANNING, AND CONTROL

Practice Exercises

Contributions from Tito Fernandez, Kevin Lynch, Huan Weng, and Zack Woodruff

November 29, 2018

This is a supplemental document to

Modern Robotics
Mechanics, Planning, and Control
Kevin M. Lynch and Frank C. Park
Cambridge University Press, 2017

Original material from this document may be reused provided proper citation is given. More information on the book, including a downloadable preprint, software, videos, online courses, and a feedback form can be found at <http://modernrobotics.org>. Comments are welcome!

Contents

1	Introduction	1
2	Practice Exercises on Configuration Space	3
2.1	Practice Exercises	3
2.2	Solutions	9
3	Practice Exercises on Rigid-Body Motions	15
3.1	Practice Exercises	15
3.2	Solutions	25
4	Practice Exercises on Forward Kinematics	31
4.1	Practice Exercises	31
4.2	Solutions	36
5	Practice Exercises on Velocity Kinematics and Statics	39
5.1	Practice Exercises	39
5.2	Solutions	43
6	Practice Exercises on Inverse Kinematics	47
6.1	Practice Exercises	47
6.2	Solutions	51
7	Practice Exercises on Kinematics of Closed Chains	53
7.1	Practice Exercises	53
7.2	Solutions	53
8	Practice Exercises on Dynamics of Open Chains	55
8.1	Practice Exercises	55
8.2	Solutions	62

9 Practice Exercises on Trajectory Generation	73
9.1 Practice Exercises	73
9.2 Solutions	78
10 Practice Exercises on Motion Planning	83
10.1 Practice Exercises	83
10.2 Solutions	83
11 Practice Exercises on Robot Control	85
11.1 Practice Exercises	85
11.2 Solutions	90
12 Practice Exercises on Grasping and Manipulation	95
12.1 Practice Exercises	95
12.2 Solutions	95
13 Practice Exercises on Wheeled Mobile Robots	97
13.1 Practice Exercises	97
13.2 Solutions	98

Chapter 1

Introduction

These exercises are designed to give you practice with the concepts, the calculations, and the software associated with the book. To get the most out of these practice exercises, you are strongly encouraged not to look at the solutions until you have given your best effort to solve them. You are more likely to retain what you have learned when you work through the problem yourself instead of just reading the solution.

Chapter 2

Practice Exercises on Configuration Space

2.1 Practice Exercises

Practice exercise 2.1 The experimental surgical manipulator shown in Figure 2.1, developed at the National University of Singapore, is a parallel mechanism with three identical legs, each with a prismatic joint and two universal joints (the joints are marked for one of the legs). Use Grübler's formula to calculate the number of degrees of freedom of this mechanism.

Practice exercise 2.2

- (a) Three rigid bodies move in space independently. How many degrees of freedom does this system of three bodies have?

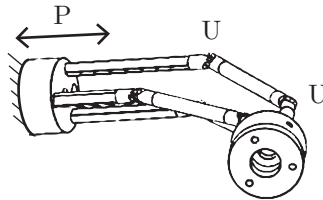

Figure 2.1: A miniature parallel surgical manipulator with three PUU legs.

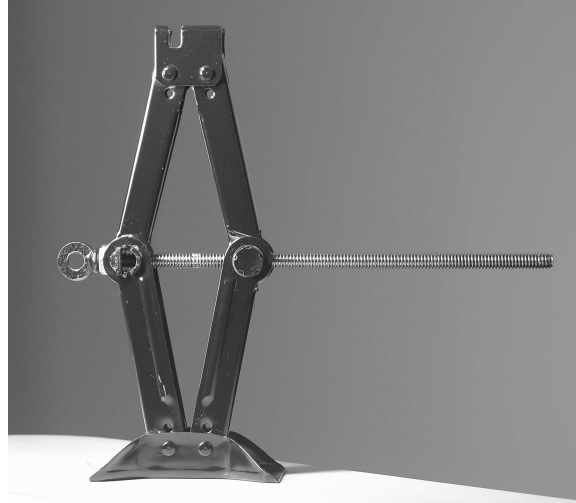

Figure 2.2: A scissor jack (also known as a scissor lift). Image courtesy of Wikipedia.

- (b) Now you constrain them so that each body must make contact with at least one of the other two bodies. (The bodies are allowed to slide and roll relative to each other, but they must remain in contact.) How many degrees of freedom does this system of three bodies have?

Practice exercise 2.3 Figure 2.2 shows a scissor jack. As you turn the screw, the jack goes up and down. The mechanical advantage provided by the mechanism allows a single person to jack up a car to change a tire.

Think about what rigid bodies and joints must be present in the scissor jack. You may not be able to see all of them in the image. Use Grübler's formula to calculate the number of degrees of freedom. Does your answer agree with what you know about how a scissor jack works? If not, can you explain why?

Practice exercise 2.4 Figure 2.3 shows a table lamp that moves only in the plane of the page. Use Grübler's formula to calculate the number of degrees of freedom.

Practice exercise 2.5 A unicycle is controlled moving on a rigid balance beam as shown in Figure 2.4. Suppose the wheel is always touching the beam with no sliding, answer the following questions in terms of \mathbb{R} , S , T , and I (a one-dimensional closed interval).



Figure 2.3: A table lamp that moves only in the plane of the page.



Figure 2.4: A unicycle on a rigid balance beam.

- (a) Give a mathematical description of the C-space of the unicycle when it remains upright and is constrained to move in the 2-dimensional plane of the page.
- (b) Give a mathematical description of the C-space of the unicycle when it remains upright, it moves in a 3-dimensional space, and the beam has nonzero width.

Practice exercise 2.6 Explain why $S^1 \times S^1 = T^2$, not S^2 . In other words, explain why the C-space of a spherical pendulum (S^2) is not topologically equivalent to the C-space of a 2R robot (T^2), even though the configurations of both would typically be described by two angles. If you think the C-space of a 2R robot is topologically equivalent (*homeomorphic*) to S^2 , propose a continuous mapping between points on a sphere and the independent joint angles of a 2R robot.

Practice exercise 2.7 Assume your arm has 7 dof and you constrain your hand to be at a fixed configuration (e.g., your palm is flat against a table).

- What is an explicit representation of the arm's configuration?
- What is an implicit representation?
- What does the set of feasible configurations look like in the 7-dimensional configuration space of the unconstrained arm?

Practice exercise 2.8 Imagine a C-space described as a circle in an (x, y) plane, of radius 2 centered at $(3, 0)$. What is an implicit representation of this one-dimensional C-space? If you were to decide to parameterize the one-dimensional C-space by the single parameter θ , give a mapping from θ to (x, y) .

Practice exercise 2.9 Consider the 2D quadcopter and rod shown in Figure 2.5. The rod is attached to the quadcopter by a revolute joint, and you are given the task of balancing the rod upright (a flying version of the classic cart pendulum problem). Assume the configuration of the quadcopter center is described by (x_q, y_q, θ_q) and the configuration of the rod center is described as (x_r, y_r, θ_r) where θ_q and θ_r are measured with respect to the world x axis. The length of the rod is $2l$ and the height and width of the quadcopter body are $2h$ and $2w$ respectively.

- Solve for the configuration constraints that keep the rod and quadcopter connected.
- Express these as a Pfaffian constraint where $q = [x_q \ y_q \ \theta_q \ x_r \ y_r \ \theta_r]^T$.

Practice exercise 2.10 Consider the parallel SCARA robot shown in Figure 2.6. The robot is controlled by two rotational motors located in the base, and one rotational and one prismatic motor at the end effector. Assume each of the links of the parallel mechanism are length 1 m, the prismatic joint has a maximum travel of 1 m, and the separation distance of the base motors is 0.5 m.

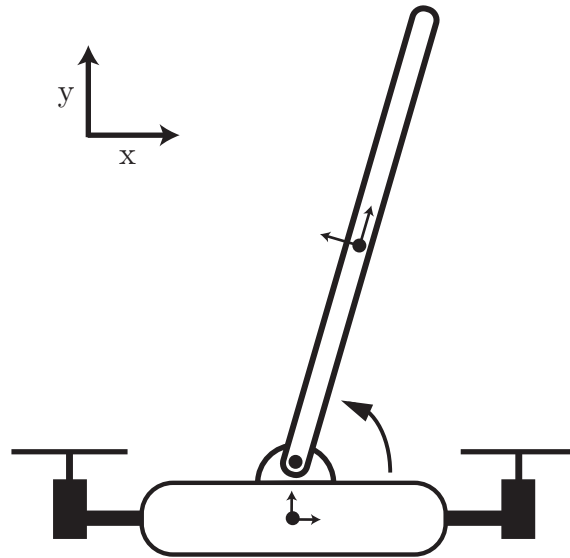

Figure 2.5: 2D quadcopter balancing a rod

Assume no collisions between the links, and that the end effector y -coordinate is constrained to be greater than zero.

- Sketch the workspace of the end effector.
- What are some benefits and drawbacks of making a parallel rather than a serial SCARA robot?

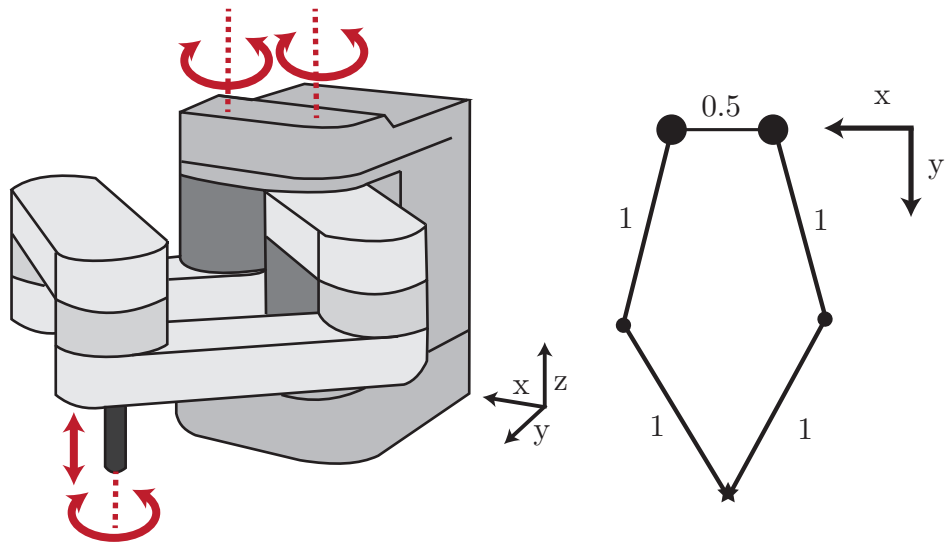

Figure 2.6: Parallel SCARA robot and a skeleton top view.

2.2 Solutions

Solution 2.1 There are $N = 8$ links (two links in each leg, ground, and the moving platform). There are $J = 9$ joints (three prismatic joints and six universal joints). The joints have a total of $3(1) + 6(2) = 15$ degrees of freedom. By Grübler's formula,

$$\text{dof} = 6(8 - 1 - 9) + 15 = 3.$$

Solution 2.2

- (a) $3(6) = 18$.
- (b) The system of three bodies is now subject to two equality constraints. For example, if the three bodies are called A, B, and C, the constraints could be written as the two equations $\text{dist}(A,B) = 0$ and $\text{dist}(B,C) = 0$. These two constraints subtract two degrees of freedom, so there are 16 degrees of freedom now.

Solution 2.3 See Figure 2.7 for work. Note that there are two extra cross pieces behind the two side joints that are not visible from the image. The result of Grübler's formula does NOT agree with the known solution of 1 DOF. This is due to the symmetry of this problem, causing certain constraints to not be independent. Instead, the formula provides a lower bound, and the known solution of 1 DOF is indeed above that lower bound.

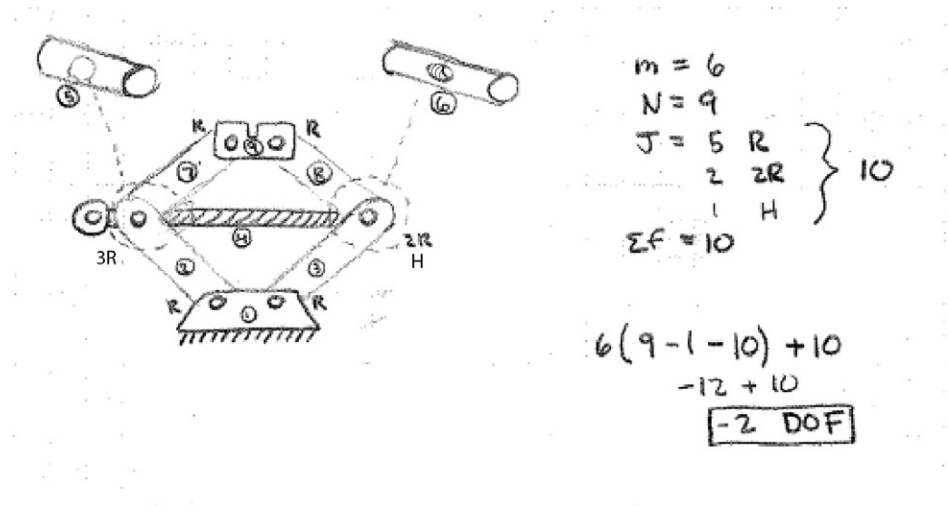

Figure 2.7: Written solution to scissor jack problem.

Solution 2.4 Despite all the links and revolute joints, this mechanical system behaves similarly to a 3R robot arm, since each set of two revolute joints acts as a single hinge.

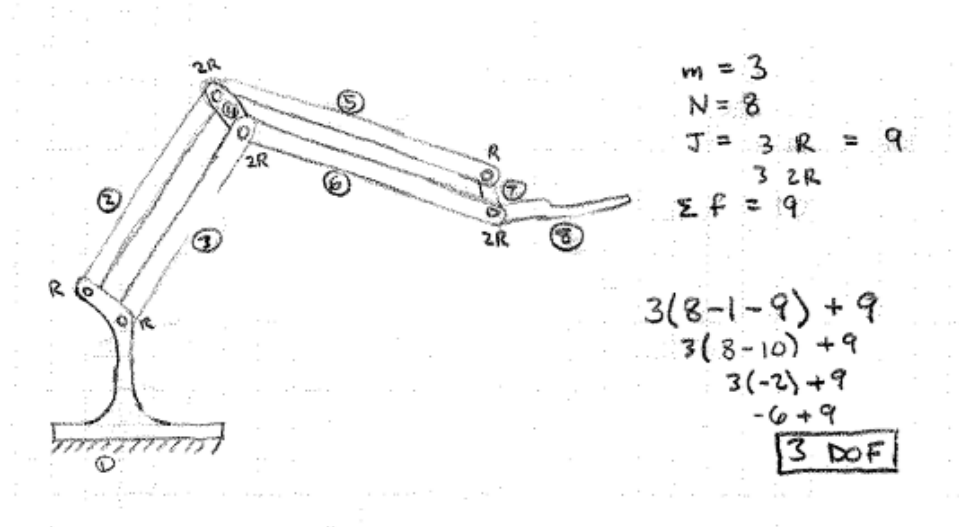

Figure 2.8: Written solution to lamp problem.

Solution 2.5

- (a) I : the point of contact on the beam (which determines the angle of the wheel, since rolling is enforced). If we treat the allowed contact points on the beam as an open interval, then the space is topologically equivalent to \mathbb{R} .
- (b) $I^2 \times T^2$: intervals correspond to limited beam contact locations, S^1 for heading direction of wheel, and S^1 for the point of contact on the wheel.

Solution 2.6 For two spaces to be topologically equivalent, there must be a *homeomorphism* relating the two. A homeomorphism is a mapping from one space X (e.g., S^2) to another space Y that (1) is one-to-one, (2) “onto” (meaning the mapping from X to Y covers all of Y), (3) continuous, and (4) has a continuous inverse. A homeomorphism is the mathematical term for the functions that can only deform the space, not cut, glue, or change its dimension.

There is no homeomorphism between S^2 and T^2 . When you poke a hole in S^2 to get T^2 , for example, suddenly points that were neighbors to each other (at the point where you poked the hole) are no longer neighbors; this cannot

occur with a continuous mapping.

Solution 2.7

- (a) The explicit representation is θ , the angle to the elbow about a line connecting the shoulder to the palm.
- (b) The implicit representation is $(\theta_1, \theta_2, \theta_3, \theta_4, \theta_5, \theta_6, \theta_7)$ in the 7-dimensional space, plus 6 equations constraining the position (3 dof) and orientation (3 dof) of the palm.
- (c) A closed interval of a 1-dimensional curve in that 7-dimensional space.

Solution 2.8 Implicit: (x, y) such that $(x - 3)^2 + y^2 = 4$. Explicit: $x = 3 + 2 \cos \theta$, $y = 2 \sin \theta$.

Solution 2.9 Note: opposite signs are also correct for the following solutions.

- (a) Configuration constraints:

$$\begin{aligned} x_r - \ell \cos(\theta_r) &= x_q - h \sin(\theta_q) \\ y_r - \ell \sin(\theta_r) &= y_q + h \cos(\theta_q). \end{aligned} \quad (2.1)$$

- (b) $A(q)\dot{q} = 0$, where $q = [x_q \ y_q \ \theta_q \ x_r \ y_r \ \theta_r]^T$, $\dot{q} = [\dot{x}_q \ \dot{y}_q \ \dot{\theta}_q \ \dot{x}_r \ \dot{y}_r \ \dot{\theta}_r]^T$

$$A(q) = \begin{bmatrix} 1 & 0 & -h \cos(\theta_q) & -1 & 0 & -\ell \sin(\theta_r) \\ 0 & 1 & -h \sin(\theta_q) & 0 & -1 & \ell \cos(\theta_r) \end{bmatrix} \quad (2.2)$$

Solution 2.10

- (a) The top view of the workspace is shown by the shaded region in Figure 2.9, and is the intersection of two circles. To solve for the workspace area, sum the area of the two circle sectors and subtract the triangle area (formed when the arms are fully extended in the y position) that is counted twice. The workspace volume is then the 3D extrusion of this shape into the page by the reach of the prismatic joint.
- (b) The parallel structure has the benefit of being more rigid and having more of the motor mass concentrated at the base. One drawback is that the parallel SCARA has a smaller workspace compared to a comparable serial SCARA arm.

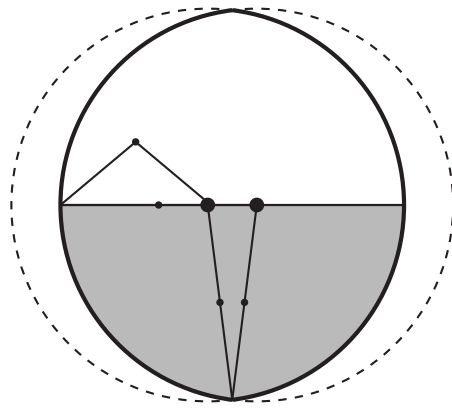

Figure 2.9: Parallel SCARA robot workspace solution

Chapter 3

Practice Exercises on Rigid-Body Motions

3.1 Practice Exercises

Practice exercise 3.1 The mobile manipulator in Figure 3.1 needs to orient its gripper to grasp the block. For subsequent placement of the block, we have decided that the orientation of the gripper relative to the block, when the gripper grasps the block, should be R_{eg} . Our job is to determine the rotation operator to apply to the gripper to achieve this orientation relative to the block.

Figure 3.1 shows the fixed world frame $\{a\}$, the mobile robot's chassis frame $\{b\}$, the gripper frame $\{c\}$, the RGBD camera (color vision plus depth, like the Kinect) frame $\{d\}$, and the object frame $\{e\}$. Because we put the camera at a known location in space, we know R_{ad} . The camera reports the configuration of $\{e\}$ relative to $\{d\}$, so we know R_{de} . From the mobile robot's localization procedure (e.g., vision-based localization or odometry) we know R_{ab} . From the robot arm's forward kinematics we know R_{bc} .

- (a) In terms of the four known rotation matrices R_{ad} , R_{de} , R_{ab} , and R_{bc} , and using only matrix multiplication and the transpose operation, express the current orientation of the gripper relative to the block, R_{ec} .
- (b) To align the gripper properly, you could apply to it a rotation R_1 expressed in terms of axes in the gripper's $\{c\}$ frame. What is R_1 , in terms of the five known rotation matrices $(R_{ad}, R_{de}, R_{ab}, R_{bc}, R_{eg})$, matrix multiplication, and transpose?

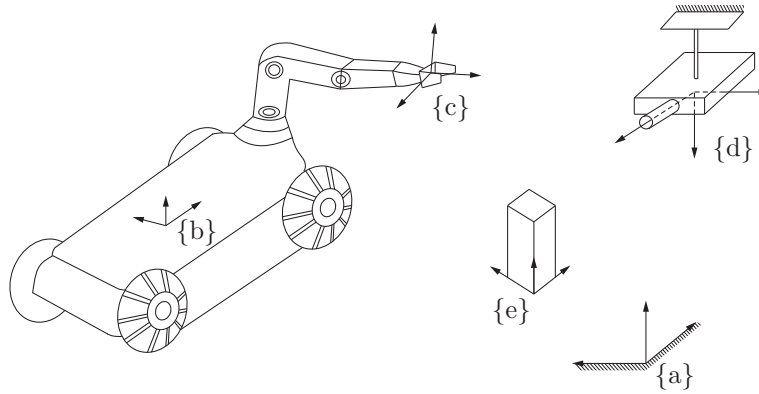

Figure 3.1: The fixed world frame $\{a\}$, the mobile robot's chassis frame $\{b\}$, the gripper frame $\{c\}$, the RGBD camera frame $\{d\}$, and the object frame $\{e\}$.

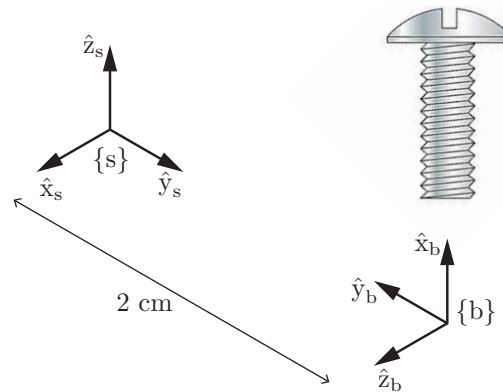

Figure 3.2: As the machine screw goes into a tapped hole, it advances linearly by 4π mm every full rotation of the screw.

- (c) The same rotation could be written R_2 , in terms of the axes of the frame of the mobile base $\{b\}$. What is R_2 ?

Practice exercise 3.2 Figure 3.2 shows a screw, a frame $\{b\}$, and a frame $\{s\}$. The \hat{x}_b -axis of $\{b\}$ is along the axis of the screw, and the origin of the frame $\{s\}$ is displaced by 2 cm, along the \hat{y}_b -axis, from the $\{b\}$ frame. The \hat{z}_s -axis is aligned with \hat{x}_b and the \hat{x}_s -axis is aligned with \hat{z}_b .

Taking note of the direction of the screw's threads, as the machine screw goes

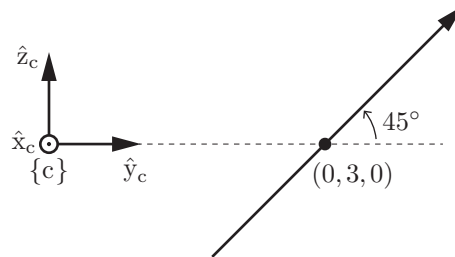

Figure 3.3: A screw axis in the (\hat{y}_c, \hat{z}_c) plane.

into a tapped hole driven by a screwdriver rotating at 3 radians per second, what is the screw's twist expressed in $\{b\}$, \mathcal{V}_b ? What is the screw axis expressed in $\{b\}$, \mathcal{S}_b ? What is \mathcal{V}_s ? What is \mathcal{S}_s ? Give units as appropriate.

Practice exercise 3.3 A wrench F and a twist V are represented in $\{a\}$ as \mathcal{F}_a and \mathcal{V}_a , respectively, and they are represented in $\{b\}$ as \mathcal{F}_b and \mathcal{V}_b . Without consulting any other source, and using the facts that $(AB)^T = B^T A^T$, that the adjoint of the transformation matrix T_{ab} can be used to change the frame of representation of a twist from the $\{a\}$ frame to the $\{b\}$ frame, and that the scalar power generated (or dissipated) by applying a wrench F along a twist V is independent of the frame of reference, show that $\mathcal{F}_a = [\text{Ad}_{T_{ba}}]^T \mathcal{F}_b$. (The ability to derive this result is useful for your understanding of it.)

Practice exercise 3.4 Figure 3.3 shows a screw axis in the (\hat{y}_c, \hat{z}_c) plane, at a 45° angle with respect to the \hat{y}_c -axis. (The \hat{x}_c -axis points out of the page.) The screw axis passes through the point $(0, 3, 0)$.

- If the pitch of the screw is $h = 10$ linear units per radian, what is the screw axis \mathcal{S}_c ? Make sure you can also write this in its $se(3)$ form $[\mathcal{S}_c]$, too.
- Using your answer to (a), if the speed of rotation about the screw axis is $\dot{\theta} = \sqrt{2}$ rad/s, what is the twist \mathcal{V}_c ?
- Using your answer to (a), if a frame initially at $\{c\}$ rotates by $\theta = \pi/2$ about the screw axis, yielding a new frame $\{c'\}$, what are the exponential coordinates describing the configuration of $\{c'\}$ relative to $\{c\}$?
- What is $T_{cc'}$, corresponding to the motion in part (c)?
- Now imagine that the axis in Figure 3.3 represents a wrench: a linear force along the axis and a moment about the axis (according to the right-hand rule). The linear force in the direction of the axis is 20 and the moment about the axis is 10. What is the wrench \mathcal{F}_c ?

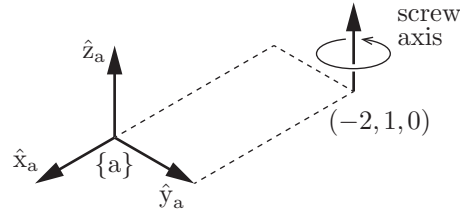

Figure 3.4: A zero-pitch screw axis.

Practice exercise 3.5 Let $T_{sb} \in SE(3)$ represent the configuration of the frame $\{b\}$ relative to $\{s\}$. (We sometimes write this simply as T .) If $\{b\}$ moves over time, you could represent its velocity as \dot{T}_{sb} (or simply \dot{T}), the time derivative of T_{sb} . You should think of this velocity as a twist of the entire space (to which the moving frame is attached). But we know that the velocity should be representable by only six values, and \dot{T}_{sb} could have 12 unique nonzero values (the top three rows of the 4×4 matrix; the bottom row will be all zeros, since the bottom row of a transformation matrix is always the constant $[0 \ 0 \ 0 \ 1]$).

Instead, we could post-multiply \dot{T}_{sb} by T_{bs} , i.e., $\dot{T}_{sb} T_{bs} = \dot{T} T^{-1} = \dot{T}_{ss}$. This post-multiplication has the effect of representing the velocity in the $\{s\}$ frame, getting rid of the dependence on the current $\{b\}$ frame. What do we call the quantity $\dot{T} T^{-1}$? How many values are needed to uniquely specify it?

We could also pre-multiply \dot{T}_{sb} by T_{bs} to get $T_{bs} \dot{T}_{sb} = T^{-1} \dot{T} = \dot{T}_{bb}$. This pre-multiplication has the effect of representing the velocity in the $\{b\}$ frame, getting rid of the dependence on the $\{s\}$ frame. What do we call the quantity $T^{-1} \dot{T}$?

Practice exercise 3.6 The zero-pitch screw axis in Figure 3.4, aligned with \hat{z}_a , passes through the point $(-2, 1, 0)$ in the $\{a\}$ frame. What is the twist \mathcal{V}_a if we rotate about the screw axis at a speed $\dot{\theta} = 5$ rad/s?

Practice exercise 3.7 A wrench F is represented in the $\{c\}$ frame as \mathcal{F}_c . If $T_1 = T_{ab}$ is the configuration of the $\{b\}$ frame relative to the $\{a\}$ frame, and $T_2 = T_{ac}$ is the configuration of the $\{c\}$ frame relative to the $\{a\}$ frame, express

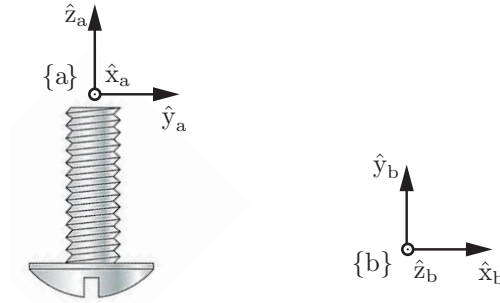

Figure 3.5: A machine screw. Notice the direction of the threads.

\mathcal{F}_b in terms of T_1 , T_2 , \mathcal{F}_c , and any math operations you need.

Practice exercise 3.8 Let the orientation of $\{b\}$ relative to $\{a\}$ be

$$R_{ab} = \begin{bmatrix} 1 & 0 & 0 \\ 0 & 0 & -1 \\ 0 & 1 & 0 \end{bmatrix}$$

and a point p be represented in $\{a\}$ as $p_a = (1, 2, 3)$. What is p_b ? (Give a numeric 3-vector.)

Practice exercise 3.9 Consider three frames, $\{a\}$, $\{b\}$, and $\{c\}$. You know the representations of these frames in terms of the others, e.g., T_{ab} and T_{bc} (and therefore you can derive T_{ac} and the inverses of these matrices). Give a mathematical expression for \mathcal{V}_a , the twist (expressed in $\{a\}$) you would need to follow for t seconds to move the $\{b\}$ frame to be coincident with the $\{c\}$ frame. Or, if you prefer, give an expression for $[\mathcal{V}_a]$, the $se(3)$ representation of \mathcal{V}_a . Your answer should be symbolic (no numbers), and it should use t , any of the transformation matrices you need, and any math operations you need. If it is helpful, you can use the operation $\text{vec} : se(3) \rightarrow \mathbb{R}^6$ to get the vector representation of an element of $se(3)$, e.g., $\text{vec}([\mathcal{V}]) = \mathcal{V}$.

Practice exercise 3.10 Figure 3.5 shows a machine screw. As it advances into a tapped hole, it moves 5 mm linearly for every radian of rotation. A frame $\{a\}$ has its \hat{z}_a -axis along the axis of the screw and its \hat{x}_a -axis out of the page. The frame $\{b\}$ has its origin at $p_a = (0, 3, -2)$ mm and its orientation is shown in the figure (\hat{z}_b is out of the page). Use mm as your linear units and radians as your angular units.

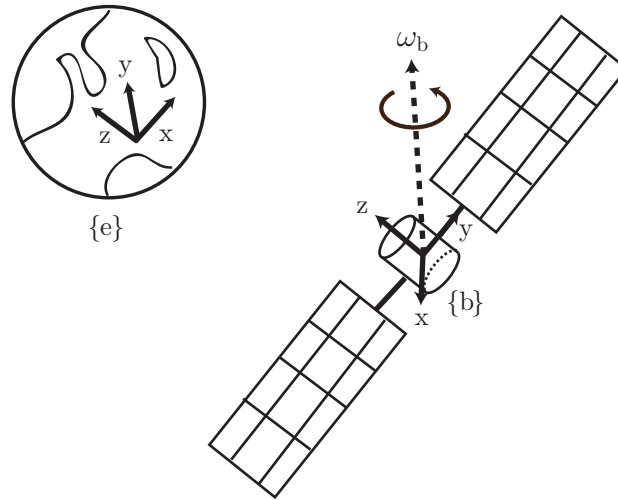

Figure 3.6: Satellite rotating in space.

- What is the screw axis \mathcal{S}_a corresponding to advancing into a tapped hole? Give a numerical 6-vector.
- What is the screw axis \mathcal{S}_b ? Give a numerical 6-vector.
- What is $[\mathcal{S}_b]$?
- From the initial configuration T_{ab} shown in the figure, the $\{b\}$ frame follows the screw an angle θ , ending at the final configuration $T_{ab'}$. If we write $T_{ab'} = TT_{ab}$, what is T ? Express this symbolically (don't write numbers), using any of \mathcal{S}_a , \mathcal{S}_b , θ , and any math operations you need.
- Referring to the previous question, if we instead write $T_{ab'} = T_{ab}T$, what is T ? Again, express this symbolically (don't write numbers), using any of \mathcal{S}_a , \mathcal{S}_b , θ , and any math operations you need.

Practice exercise 3.11 Consider the satellite and Earth shown in Figure 3.6. Let $\omega_b = (0, 1, 1)$ be the angular velocity of the satellite expressed in the satellite body frame $\{b\}$. Assume a fixed Earth frame $\{e\}$ (a geocentric view of the universe like the ancient Greeks had).

- Solve for the coordinate axis velocities of $\{b\}$ (\dot{x}_b , \dot{y}_b , and \dot{z}_b) represented in the $\{b\}$ frame. Sketch the velocity vectors on the figure above to confirm that your solutions make sense.

- (b) The orientation of the $\{b\}$ frame is equivalent to the $\{e\}$ frame after it has been rotated -90 degrees about its \hat{z}_e -axis. Solve for ω_e , the satellite angular velocity represented in $\{e\}$. Sketch the velocity vectors on the figure above to confirm that your solution makes sense.
- (c) Solve for \dot{R}_{eb} , the time derivative of the body orientation expressed in $\{e\}$.
- (d) Give the $so(3)$ representation of the angular velocity in both the Earth and the body frame.

Practice exercise 3.12 Consider again the satellite and Earth shown in Figure 3.6.

- (a) If the given rotational velocity $\omega_b = (0, 1, 1)$ was instead the exponential coordinates for a rotation, solve for the axis-angle representation and the corresponding rotation matrix.
- (b) After rotating and orbiting the Earth for some time, the relative orientation of the Earth and satellite is given as

$$R_{eb'} = \begin{bmatrix} 0 & -\sqrt{2}/2 & \sqrt{2}/2 \\ 1 & 0 & 0 \\ 0 & \sqrt{2}/2 & \sqrt{2}/2 \end{bmatrix}.$$

Find the axis-angle representation that describes the rotation from the initial body frame $\{b\}$ to the new body frame $\{b'\}$.

Practice exercise 3.13 Consider the scene in Figure 3.7 of a once peaceful park overrun by robots. Frames are shown attached to the tree $\{t\}$, robot chassis $\{c\}$, manipulator $\{m\}$, and quadcopter $\{q\}$. The distances shown in the figure are $d_1 = 4$ m, $d_2 = 3$ m, $d_3 = 6$ m, $d_4 = 5$ m, $d_5 = 3$ m. The manipulator is at a position $p_{cm} = (0, 2, 1)$ m relative to the chassis frame $\{c\}$, and $\{m\}$ is rotated from $\{c\}$ by 45 degrees about the \hat{x}_c -axis.

- (a) Give the transformation matrices representing the quadcopter frame $\{q\}$, chassis frame $\{c\}$, and manipulator frame $\{m\}$ in the tree frame $\{t\}$.
- (b) Assume that the position controller for the manipulator on the mobile robot is referenced to the chassis frame $\{c\}$. What position should you command the gripper to go to if you would like to snatch the quadcopter out of the sky?
- (c) You are tasked to move the mobile robot so that the chassis origin is directly underneath the quadcopter and its frame is aligned with the tree frame. Assume the mobile robot chassis controller takes transformation matrices in the chassis frame as inputs. What transformation should you command the robot to follow?

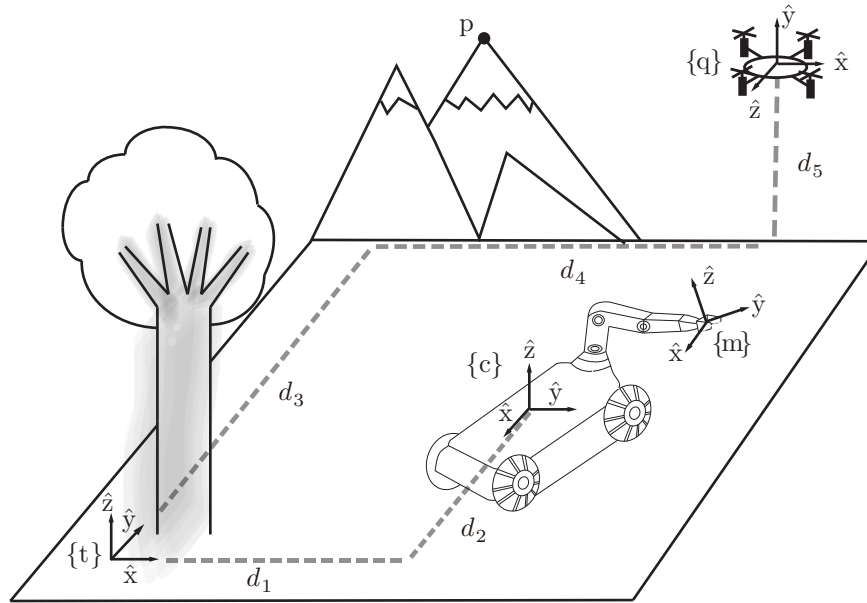

Figure 3.7: A tree, mobile manipulator, and flying robot in a park and the corresponding reference frames.

Practice exercise 3.14 Consider the scene in Figure 3.8 of a quadcopter $\{q\}$ flying near a tree $\{t\}$ and house $\{h\}$. The quadcopter is at a position $p_{tq} = (10, 5, 5)$ m expressed in the tree frame $\{t\}$, and the house is at a position $p_{th} = (0, 10, 10)$ m expressed in the tree frame $\{t\}$. The quadcopter is flying upwards with a velocity of 1 m/s, and rotating with a velocity of 1 rad/s.

- Calculate the quadcopter's twist in $\{q\}$ and $\{t\}$.
- Use the adjoint map to express the twist in the house frame $\{h\}$.

Practice exercise 3.15 Consider the cube with side lengths $l = 2$ m and the ant shown in Figure 3.9. Frames $\{b\}$ and $\{c\}$ show the ant at the midpoint of the cube edges.

- Solve for the screw axis \mathcal{S}_b and angle θ corresponding to the transformation

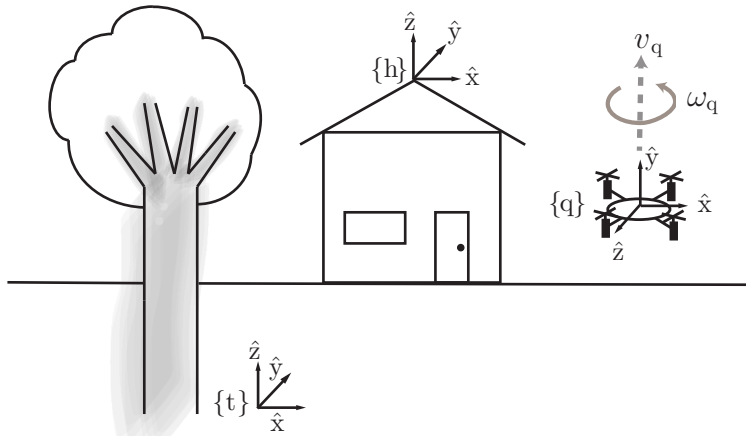

Figure 3.8: A tree, and flying robot in a park and the corresponding reference frames.

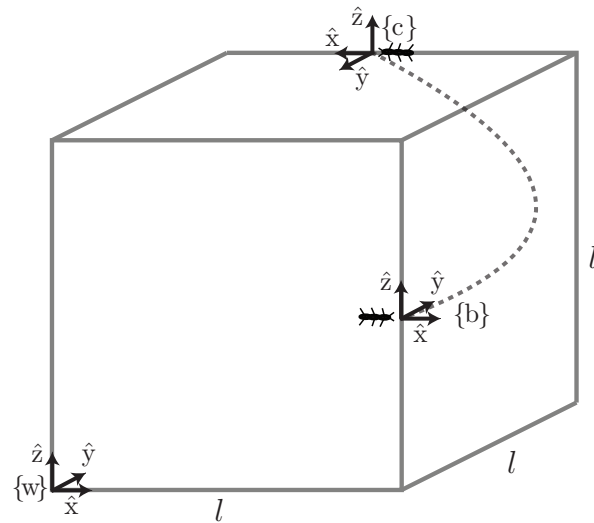

Figure 3.9: An ant shown at different positions on a cube.

from $\{b\}$ to $\{c\}$.

(b) Sketch the location of the screw axis on the figure.

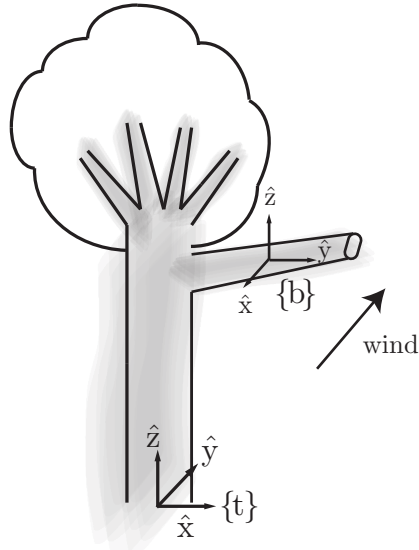

Figure 3.10: A tree and a frame attached to its branch.

- (c) Use the appropriate adjoint map to find \mathcal{S}_w , the screw axis representation in the $\{w\}$ frame.
- (d) How could you solve for \mathcal{S}_w without using the adjoint map?

Practice exercise 3.16 Consider the scene in Figure 3.10 of a tree $\{t\}$ and a frame $\{b\}$ attached to its branch. The figure shows a strong wind that applies a force of 100 N at the center of frame $\{b\}$. Assume the branch has a mass of 50 kg centered at frame $\{b\}$ as well. The position of the branch frame $\{b\}$ in the tree frame $\{t\}$ is $p_{tb} = (2, 1, 3)$ m.

- (a) What is the wrench \mathcal{F}_b due to the wind and the branch's weight?
- (b) What is this wrench in the tree frame $\{t\}$?

3.2 Solutions

Solution 3.1

(a)

$$\begin{aligned} R_{ec} &= R_{ed}R_{da}R_{ab}R_{bc} \\ &= R_{de}^T R_{ad}^T R_{ab} R_{bc}. \end{aligned}$$

(b)

$$\begin{aligned} R_{ec}R_1 = R_{eg} &\rightarrow R_1 = R_{ec}^T R_{eg} \\ &= (R_{de}^T R_{ad}^T R_{ab} R_{bc})^T R_{eg} \\ &= R_{bc}^T R_{ab}^T R_{ad} R_{de} R_{eg} \quad (= R_{cg}). \end{aligned}$$

(c)

$$R_2 = R_{bc}R_1 = R_{bc}R_{cg} = R_{bc}R_{bc}^T R_{ab}^T R_{ad} R_{de} R_{eg} = R_{ab}^T R_{ad} R_{de} R_{eg} \quad (= R_{bg}).$$

Solution 3.2 The threads of this screw are the typical right-handed threads, which means that the screw, when viewed from the top, rotates clockwise when it advances into a tapped hole. In other words, the fingers of your right hand curl in the direction of rotation of the screw when your right thumb points downward on the page, in the negative direction of the upward-pointing \hat{x}_b -axis. Since the screwdriver rotates at 3 rad/s, the screw also rotates at 3 rad/s, so the angular component of the twist, expressed in $\{b\}$, is $\omega_b = (-3 \text{ rad/s}, 0, 0)$. Since radians and seconds are the SI units for angle and time, respectively, you could write $(-3, 0, 0)$ and assume the default SI units. You could also write $(-3(180/\pi) \text{ deg/s}, 0, 0)$, but that would be unusual.

The pitch of the screw is 4π mm per revolution, or 2 mm/rad. So as the screw is rotated at 3 rad/s, it moves linearly in the $-\hat{x}_b$ direction at $(2 \text{ mm/rad})(3 \text{ rad/s}) = 6 \text{ mm/s}$. So the linear component of the twist expressed in $\{b\}$ is $(-6 \text{ mm/s}, 0, 0)$, or, in SI units, $v_b = (-0.006 \text{ m/s}, 0, 0)$. So, in SI units, the entire twist is $\mathcal{V}_b = (\omega_b, v_b) = (-3, 0, 0, -0.006, 0, 0)$.

The corresponding screw axis expressed in $\{b\}$ is the normalized version of \mathcal{V}_b where the magnitude of the angular velocity is unit. The magnitude of ω_b is 3, so divide the twist by 3 to get $\mathcal{S}_b = (-1, 0, 0, -0.002, 0, 0)$. We can write $\mathcal{V}_b = \mathcal{S}_b \dot{\theta}$ where $\dot{\theta} = \|\omega_b\| = 3$.

The screw axis could also be represented in the $\{b\}$ frame by the collection $\{q_b, \hat{s}_b, h\}$, where a point q_b on the axis is $(0, 0, 0)$ (expressed in $\{b\}$), the axis direction is $\hat{s}_b = (-1, 0, 0)$, and the pitch is $h = 0.002$.

In the $\{s\}$ frame, the axis of rotation is aligned with the $-\hat{z}_s$ -axis, so $\omega_s = (0, 0, -3)$. A point at the origin of $\{s\}$, rigidly attached to the advancing screw, has a downward linear component of -0.006 m/s in the $-\hat{z}_s$ direction (i.e., $(0, 0, -0.006)$) from the downward motion of the screw. But it also has a linear component in the $-\hat{x}_s$ direction from the rotation of the screw. The point at the origin of $\{s\}$ can be expressed as $q_b = (0, 0.02, 0)$ in terms of $\{b\}$ coordinates, so the linear motion at $\{s\}$ due to the rotation of the screw is $\omega_b \times q_b = (0, 0, -0.06)$. In the $\{s\}$ frame, this is $(-0.06, 0, 0)$. (Imagine a turntable rotating about the screw axis and the resulting motion of a point at $\{s\}$.) So the total linear motion at $\{s\}$, expressed in $\{s\}$, is $v_s = (0, 0, -0.006) + (-0.06, 0, 0) = (-0.06, 0, -0.006)$. Therefore, $\mathcal{V}_s = (0, 0, -3, -0.06, 0, -0.006)$. The screw axis is $\mathcal{S}_s = (0, 0, -1, -0.02, 0, -0.002)$ and $\mathcal{V}_s = \mathcal{S}_s \theta$.

The screw axis could also be represented in the $\{s\}$ frame by the collection $\{q_s, \hat{s}_s, h\}$, where a point q_s on the axis is $(0, 0.02, 0)$, the axis direction is $\hat{s}_s = (0, 0, -1)$, and the pitch is $h = 0.002$. Note that $\mathcal{S}_s = (\hat{s}_s, -\hat{s}_s \times q_s + h\hat{s})$, where $h\hat{s}$ is the linear velocity due to the linear motion of the screw and $-\hat{s}_s \times q_s$ is the linear velocity due to the rotation of the screw.

You could also calculate \mathcal{V}_s and \mathcal{S}_s using $\mathcal{V}_s = [\text{Ad}_{T_{sb}}]\mathcal{V}_b$ and $\mathcal{S}_s = [\text{Ad}_{T_{sb}}]\mathcal{S}_b$.

Solution 3.3 See Chapter 3.4 of the textbook.

Solution 3.4

- Since the screw axis $\mathcal{S}_c = (\mathcal{S}_{c_\omega}, \mathcal{S}_{c_v})$ has a rotational component, \mathcal{S}_{c_ω} is a unit vector aligned with the axis, i.e., $\mathcal{S}_{c_\omega} = \hat{s} = (0, \cos 45^\circ, \sin 45^\circ) = (0, 1/\sqrt{2}, 1/\sqrt{2})$. The linear component is $\mathcal{S}_{c_v} = h\hat{s} - \hat{s} \times q$ (a linear component due to linear motion along the screw plus a linear component due to rotation about the screw), where $q = (0, 3, 0)$ and $h = 10$, i.e., $\mathcal{S}_{c_v} = (0, 10/\sqrt{2}, 10/\sqrt{2}) + (3/\sqrt{2}, 0, 0) = (3, 10, 10)/\sqrt{2}$.
- $\mathcal{V}_c = \mathcal{S}_c \theta = (0, 1, 1, 3, 10, 10)$.
- $\mathcal{S}_c \theta = (0, 1, 1, 3, 10, 10)\pi/(2\sqrt{2})$.
- You can use the MR code library to do the calculation. Use `VecTose3` to convert the exponential coordinates $\mathcal{S}_c \theta$ to their $se(3)$ representation $[\mathcal{S}_c \theta]$

and then use `MatrixExp6` to calculate

$$T_{cc'} = e^{[\mathcal{S}_c\theta]} = \begin{bmatrix} 0 & -0.71 & 0.71 & 2.12 \\ 0.71 & 0.5 & 0.5 & 12.61 \\ -0.71 & 0.5 & 0.5 & 9.61 \\ 0 & 0 & 0 & 1 \end{bmatrix}.$$

- (e) The wrench is written $\mathcal{F}_c = (m_c, f_c)$. The linear component f_c has a magnitude of 20 and is aligned with the axis shown, so $f_c = (0, 10\sqrt{2}, 10\sqrt{2})$. If the axis passed through the origin of $\{c\}$, the moment (which has magnitude 10) would be $(0, 5\sqrt{2}, 5\sqrt{2})$, but since it is displaced from the origin of $\{c\}$, there is an extra moment component due to the linear component, $q \times f_c = (0, 3, 0) \times (0, 10\sqrt{2}, 10\sqrt{2}) = (30\sqrt{2}, 0, 0)$, so the total moment is $m_c = (0, 5\sqrt{2}, 5\sqrt{2}) + (30\sqrt{2}, 0, 0) = \sqrt{2}(30, 5, 5)$. You can verify that you get the same answer using $\mathcal{F}_c = [\text{Ad}_{T_{ac}}]^T \mathcal{F}_a$, where $\{a\}$ is a frame aligned with $\{c\}$ and with an origin at $(0, 3, 0)$.

Solution 3.5 $\dot{T}T^{-1}$ is the $se(3)$ representation of the twist represented in $\{s\}$, i.e., $[\mathcal{V}_s] \in se(3)$. Only six values (the six elements of \mathcal{V}_s) are needed to specify it.

$T^{-1}\dot{T}$ is the $se(3)$ representation of the twist represented in $\{b\}$, i.e., $[\mathcal{V}_b] \in se(3)$. Only six values (the six elements of \mathcal{V}_b) are needed to specify it.

Solution 3.6 The screw axis can be written $\mathcal{S}_a = (\mathcal{S}_{\omega_a}, \mathcal{S}_{v_a})$. The angular component is $\mathcal{S}_{\omega_a} = (0, 0, 1)$, since the screw axis is aligned with \hat{z}_a . The linear component is $\mathcal{S}_{v_a} = -\mathcal{S}_{\omega_a} \times q$, where $q = (-2, 1, 0)$, so $\mathcal{S}_{v_a} = (1, 2, 0)$. The entire screw is then $\mathcal{S}_a = (0, 0, 1, 1, 2, 0)$. The twist is $\mathcal{V}_a = \dot{\theta}\mathcal{S}_a = (0, 0, 5, 5, 10, 0)$.

Solution 3.7

$$\begin{aligned} \mathcal{F}_b &= [\text{Ad}_{T_{cb}}]^T \mathcal{F}_c \text{ where } T_{cb} = T_{ac}^{-1}T_{ab} = T_2^{-1}T_1 \\ &= [\text{Ad}_{T_2^{-1}T_1}]^T \mathcal{F}_c. \end{aligned}$$

Or you could recognize $\mathcal{F}_a = [\text{Ad}_{T_{ac}^{-1}}]^T \mathcal{F}_c$ and $\mathcal{F}_b = [\text{Ad}_{T_{ab}}]^T \mathcal{F}_a$ to get $\mathcal{F}_b = [\text{Ad}_{T_1}]^T [\text{Ad}_{T_2^{-1}}]^T \mathcal{F}_c$.

Solution 3.8 $p_b = R_{ba}p_a = R_{ab}^T p_a = (1, 3, -2)$.

Solution 3.9 Below are two approaches that arrive at the same solution.

$$\begin{aligned}
T_{ac} &= e^{[\mathcal{V}_a]t} T_{ab} \\
T_{ac} T_{ab}^{-1} &= e^{[\mathcal{V}_a]t} \\
\log(T_{ac} T_{ab}^{-1}) &= [\mathcal{V}_a]t \\
\frac{1}{t} \log(T_{ac} T_{ab}^{-1}) &= [\mathcal{V}_a]
\end{aligned}$$

Or:

$$\begin{aligned}
t[\mathcal{V}_b] &= \log T_{bc} \\
[\mathcal{V}_b] &= \frac{1}{t} \log T_{bc} \\
\mathcal{V}_a &= [\text{Ad}_{T_{ab}}] \text{vec}([\mathcal{V}_b]) = \frac{1}{t} [\text{Ad}_{T_{ab}}] \text{vec}(\log T_{bc})
\end{aligned}$$

Solution 3.10

- (a) $\mathcal{S}_a = (\mathcal{S}_{\omega_a}, \mathcal{S}_{v_a})$. Since there is a rotational component about the \hat{z}_a -axis, $\mathcal{S}_{\omega_a} = (0, 0, 1)$. There is no linear component at the origin of $\{a\}$ due to the rotation, so $\mathcal{S}_{v_a} = (0, 0, 5)$, the linear motion due to the pitch of the screw. So $\mathcal{S}_a = (0, 0, 1, 0, 0, 5)$.
- (b) $\mathcal{S}_b = (\mathcal{S}_{\omega_b}, \mathcal{S}_{v_b})$. The rotational component is $\mathcal{S}_{\omega_b} = (0, 1, 0)$. The linear component is $(0, 5, 0)$ due to the pitch of the screw plus the linear motion due to the rotation of the screw, $-\mathcal{S}_{\omega_b} \times q = (0, 0, -3)$, where q is any point on the screw axis measured in the $\{b\}$ frame (e.g., $q = (-3, 2, 0)$). So $\mathcal{S}_{v_b} = (0, 5, -3)$, and $\mathcal{S}_b = (0, 1, 0, 0, 5, -3)$.

(c) $[\mathcal{S}_b] = \begin{bmatrix} 0 & 0 & 1 & 0 \\ 0 & 0 & 0 & 5 \\ -1 & 0 & 0 & -3 \\ 0 & 0 & 0 & 0 \end{bmatrix}$.

- (d) $T = e^{[\mathcal{S}_a]\theta}$. (The transformation when the screw axis is expressed in the $\{a\}$ frame.)
- (e) $T = e^{[\mathcal{S}_b]\theta}$. (The transformation when the screw axis is expressed in the $\{b\}$ frame.)

Solution 3.11

- (a) $\dot{\hat{x}}_b = (0, 1, -1)$, $\dot{\hat{y}}_b = (-1, 0, 0)$, $\dot{\hat{z}}_b = (1, 0, 0)$
- (b) $\omega_e = (1, 0, 1)$.

$$(c) \dot{R}_{eb} = \begin{bmatrix} 1 & 0 & 0 \\ 0 & 1 & -1 \\ -1 & 0 & 0 \end{bmatrix}$$

$$(d) [\omega_b] = \begin{bmatrix} 0 & -1 & 1 \\ 1 & 0 & 0 \\ -1 & 0 & 0 \end{bmatrix}, \quad [\omega_e] = \begin{bmatrix} 0 & -1 & 0 \\ 1 & 0 & -1 \\ 0 & 1 & 0 \end{bmatrix}$$

Solution 3.12

(a) $\hat{\omega} = (0, \sqrt{2}/2, \sqrt{2}/2)$, and $\theta = \sqrt{2}$.

$$R = \begin{bmatrix} 0.1559 & -0.6985 & 0.6985 \\ 0.6985 & 0.5780 & 0.4220 \\ -0.6985 & 0.4220 & 0.5780 \end{bmatrix}$$

$$(b) R_{bb'} = R_{eb}^T R_{eb'} = \begin{bmatrix} -1 & 0 & 0 \\ 0 & -\sqrt{2}/2 & \sqrt{2}/2 \\ 0 & \sqrt{2}/2 & \sqrt{2}/2 \end{bmatrix},$$

$\hat{\omega} = (0, 0.3827, 0.9239)$, and $\theta = \pi$.

Solution 3.13

(a)

$$T_{tq} = \begin{bmatrix} 1 & 0 & 0 & 5 \\ 0 & 0 & -1 & 6 \\ 0 & 1 & 0 & 3 \\ 0 & 0 & 0 & 1 \end{bmatrix}$$

$$T_{tc} = \begin{bmatrix} 0 & 1 & 0 & 4 \\ -1 & 0 & 0 & 3 \\ 0 & 0 & 1 & 0 \\ 0 & 0 & 0 & 1 \end{bmatrix}$$

$$T_{tm} = \begin{bmatrix} 0 & \sqrt{2}/2 & -\sqrt{2}/2 & 6 \\ -1 & 0 & 0 & 3 \\ 0 & \sqrt{2}/2 & \sqrt{2}/2 & 1 \\ 0 & 0 & 0 & 1 \end{bmatrix}$$

(b)

$$p_{cq} = (-3, 1, 3)$$

(c)

$$p_{cc'} = (-3, 1, 0)$$

$$R_{cc'} = R_{ct} = R'_{tc}$$

$$T_{cc'} = \begin{bmatrix} 0 & -1.0 & 0 & -3.0 \\ 1.0 & 0 & 0 & 1.0 \\ 0 & 0 & 1.0 & 0 \\ 0 & 0 & 0 & 1.0 \end{bmatrix}$$

Solution 3.14

- (a) $\mathcal{V}_b = (0, 1, 0, 0, 1, 0)$. $\mathcal{V}_t = (0, 0, 1, 5, -10, 1)$.
 (b) $\mathcal{V}_h = (0, 0, 1, -5, -10, 1)$.

Solution 3.15

- (a) $T_{wc} = T_{wb}e^{[\mathcal{S}_b]\theta}$
 $T_{wb}^{-1}T_{wc} = e^{[\mathcal{S}_b]\theta}$
 $T_{bc} = e^{[\mathcal{S}_b]\theta}$
 $\mathcal{S}_b = (0, 0, 1, 1, 0.5, 1/\pi)$, $\theta = \pi$.
 (b) Axis points in the world z direction intersecting the (x,y) coordinates (1.5,1) in the {w} frame.
 (c) $\mathcal{S}_w = [\text{Ad}_{T_{wb}}]\mathcal{S}_b$
 $\mathcal{S}_w = (0, 0, 1, 1, -1.5, 1/\pi)$, $\theta = \pi$.
 (d) $T_{wc} = e^{[\mathcal{S}_w]\theta}T_{wb}$. Can right multiply both sides by T_{wb}^{-1} and use the matrix log to solve for \mathcal{S}_w

Solution 3.16

- (a) $\mathcal{F}_b = (0, 0, 0, -100, 0, -500)$
 (b) $\mathcal{F}_t = (-800, 1000, 200, 0, 100, -500)$

Chapter 4

Practice Exercises on Forward Kinematics

4.1 Practice Exercises

Practice exercise 4.1 Figure 4.1 shows the KUKA LBR iiwa (LBR = “Leichtbauroboter,” German for lightweight robot; iiwa = “intelligent industrial work assistant”) 7R robot arm. The figure defines an $\{s\}$ frame at the base with the \hat{y}_s -axis pointing out of the page and a $\{b\}$ frame aligned with $\{s\}$ at the end-effector. The robot is at its home configuration. The screw axes for the seven joints are illustrated (positive rotation about these axes is by the right-hand rule). The axes for joints 2, 4, and 6 are aligned, and the axes for joints 1, 3, 5, and 7 are identical at the home configuration. Write M (T_{sb} when the robot is at its home configuration), the screw axes $\mathcal{S}_1, \dots, \mathcal{S}_7$ in $\{s\}$, and the

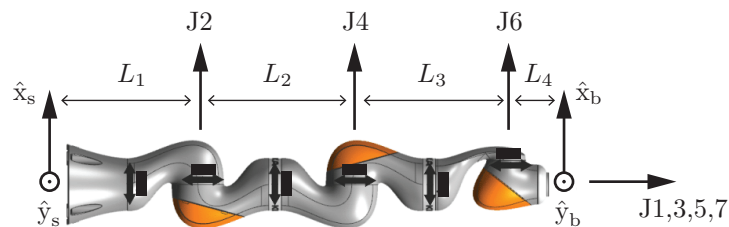

Figure 4.1: The KUKA LBR iiwa 7-dof robot.

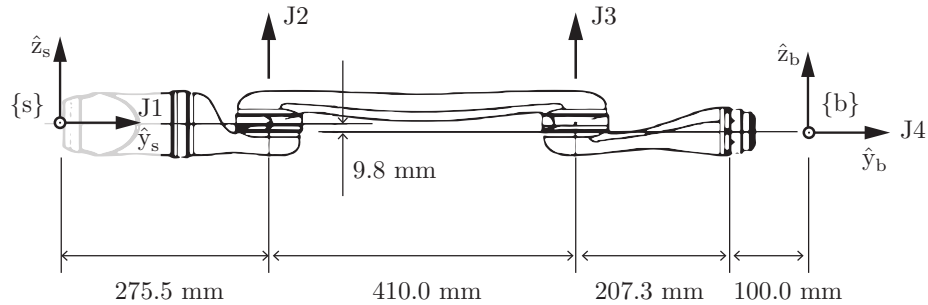

Figure 4.2: The KINOVA ultra lightweight 4-dof robot arm at its home configuration.

screw axes $\mathcal{B}_1, \dots, \mathcal{B}_7$ in $\{b\}$.

Practice exercise 4.2 Figure 4.2 shows a KINOVA ultra lightweight 4-dof robot arm at its home configuration. An $\{s\}$ frame is at its base and a $\{b\}$ frame is at its end-effector. All the relevant dimensions are shown. The \hat{y}_b -axis is displaced from the \hat{y}_s -axis by 9.8 mm, as shown in the image. Positive rotation about joint axis 1 is about the \hat{y}_s -axis (by the right-hand rule, as always) and joint axis 4 is about the \hat{y}_b -axis. Joint axes 2 and 3 are also illustrated.

- Write M (i.e., T_{sb} when the robot is at its home configuration). All entries should be numerical (no symbols or math).
- Write the space-frame screw axes $\mathcal{S}_1, \dots, \mathcal{S}_4$. All entries should be numerical (no symbols or math).
- Give the product of exponentials formula for $T_{sb}(\theta)$ for arbitrary joint angles $\theta = (\theta_1, \theta_2, \theta_3, \theta_4)$. Your answer should be purely symbolic (no numbers), using only the symbols $M, \mathcal{S}_1, \dots, \mathcal{S}_4, \theta_1, \dots, \theta_4$, and the matrix exponential.

Practice exercise 4.3 Figures 4.3 and 4.4 show a Sawyer collaborative robot in action on a factory floor. This is a 7-dof robotic arm.

- Draw a stick and cylinder model of Sawyer (similar to the examples in Chapter 4), clearly showing all links and joints.
- Assuming the home configuration is shown in Figure 4.4, write the M matrix.
- Write the space-frame and body-frame screw axes for this robot.
- What is the end-effector position when the joints are set to $(0, \frac{\pi}{2}, 0, \frac{\pi}{2}, 0, \frac{\pi}{2}, 0)$? (Hint: You might find the functions in the MR library to be useful).



Figure 4.3: A Sawyer robot.

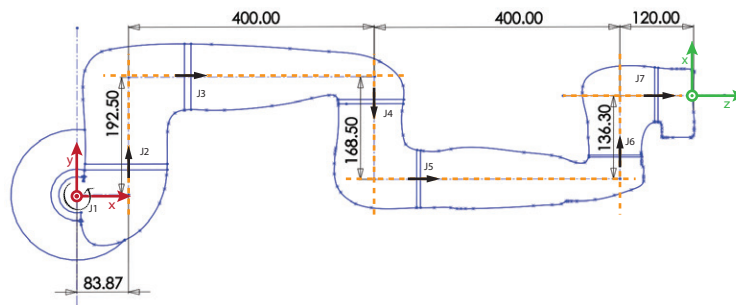

Figure 4.4: A top view of the Sawyer robot arm at its home configuration. Dimensions are in mm. Assume that the centerlines shown are the screw axes of the revolute joints. The $\{s\}$ frame is at the base of the arm. The height from the base to the first joint is 317 mm.



Figure 4.5: Da Vinci Xi surgical robot.

Practice exercise 4.4 Figure 4.5 shows a da Vinci Xi, used in several types of robot-assisted surgery. Though it is mechanically constrained to have only 3 degrees of freedom per arm, for the sake of this exercise assume each arm is a simple serial chain with 6 degrees of freedom.

- (a) Write the M matrix for the arm if its home configuration is shown in Figure 4.6.
- (b) Find the space frame screw axes for this system.
- (c) Determine the position of the end-effector if the joints are at $(0, \frac{\pi}{4}, 0, \frac{\pi}{4}, \frac{3\pi}{4}, \frac{\pi}{2})$. Again, the MR Library will prove useful here.

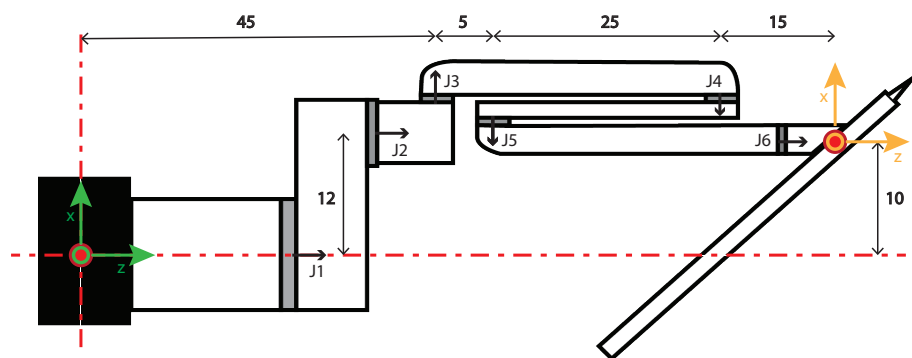

Figure 4.6: Top view of one da Vinci Xi surgical robot arm. Note that the grey regions represent R joints, green indicates the $\{s\}$ frame, and yellow represents the end-effector frame $\{b\}$ in this exercise. Dimensions are in cm.

4.2 Solutions

Solution 4.1

$$M = \begin{bmatrix} 1 & 0 & 0 & 0 \\ 0 & 1 & 0 & 0 \\ 0 & 0 & 1 & L_1 + L_2 + L_3 + L_4 \\ 0 & 0 & 0 & 1 \end{bmatrix}.$$

Lining up the screw axes as columns, we get

$$\mathcal{S}_{\text{list}} = \begin{bmatrix} 0 & 1 & 0 & 1 & 0 & 1 & 0 \\ 0 & 0 & 0 & 0 & 0 & 0 & 0 \\ 1 & 0 & 1 & 0 & 1 & 0 & 1 \\ 0 & 0 & 0 & 0 & 0 & 0 & 0 \\ 0 & L_1 & 0 & L_1 + L_2 & 0 & L_1 + L_2 + L_3 & 0 \\ 0 & 0 & 0 & 0 & 0 & 0 & 0 \end{bmatrix}$$

and

$$\mathcal{B}_{\text{list}} = \begin{bmatrix} 0 & 1 & 0 & 1 & 0 & 1 & 0 \\ 0 & 0 & 0 & 0 & 0 & 0 & 0 \\ 1 & 0 & 1 & 0 & 1 & 0 & 1 \\ 0 & 0 & 0 & 0 & 0 & 0 & 0 \\ 0 & -(L_2 + L_3 + L_4) & 0 & -(L_3 + L_4) & 0 & -L_4 & 0 \\ 0 & 0 & 0 & 0 & 0 & 0 & 0 \end{bmatrix}.$$

Solution 4.2

(a)

$$M = T_{sb}(0) = \begin{bmatrix} 1 & 0 & 0 & 0 \\ 0 & 1 & 0 & 992.8 \text{ mm} \\ 0 & 0 & 1 & -9.8 \text{ mm} \\ 0 & 0 & 0 & 1 \end{bmatrix}.$$

(b) Lining up the screw axes as columns of a matrix,

$$\mathcal{S}_{\text{list}} = \begin{bmatrix} 0 & 0 & 0 & 0 \\ 1 & 0 & 0 & 1 \\ 0 & 1 & 1 & 0 \\ 0 & 275.5 & 685.5 & 9.8 \\ 0 & 0 & 0 & 0 \\ 0 & 0 & 0 & 0 \end{bmatrix},$$

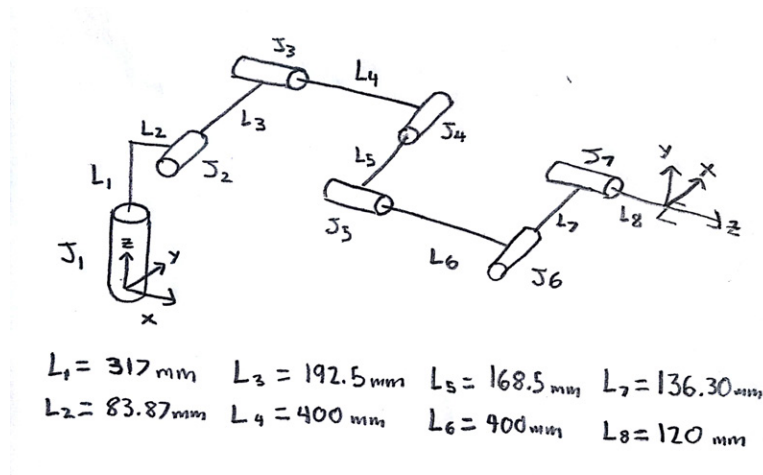

Figure 4.7: Bare bones model of a Sawyer.

where distances are measured in mm. You can get this by visualization, or by noting that $\omega_1 = \omega_4 = (0, 1, 0)$ and $\omega_2 = \omega_3 = (0, 0, 1)$ and choosing representative points on the joint axes (e.g., $q_1 = (0, 0, 0)$, $q_2 = (0, 275.5, 0)$, $q_3 = (0, 685.5, 0)$, and $q_4 = (0, 992.8, -9.8)$) and using $v_i = -\omega_i \times q_i$.

(c) $T_{sb}(\theta) = e^{[S_1\theta_1]}e^{[S_2\theta_2]}e^{[S_3\theta_3]}e^{[S_4\theta_4]}M$.

Solution 4.3

(a) See Figure 4.7.

(b)

$$M = \begin{bmatrix} 0 & 0 & 1 & 1003.9 \\ 1 & 0 & 0 & 160.3 \\ 0 & 1 & 0 & 317.0 \\ 0 & 0 & 0 & 1 \end{bmatrix}.$$

(c)

$$S_{\text{list}} = \begin{bmatrix} 0 & 0 & 1 & 0 & 1 & 0 & 1 \\ 0 & 1 & 0 & -1 & 0 & 1 & 0 \\ 1 & 0 & 0 & 0 & 0 & 0 & 0 \\ 0 & -317 & 0 & 317 & 0 & -317 & 0 \\ 0 & 0 & 317 & 0 & 317 & 0 & 317 \\ 0 & 83.87 & -192.5 & -483.87 & -24 & 883.87 & -160.3 \end{bmatrix}$$

$$\mathcal{B}_{\text{list}} = \begin{bmatrix} 0 & 1 & 0 & -1 & 0 & 1 & 0 \\ 1 & 0 & 0 & 0 & 0 & 0 & 0 \\ 0 & 0 & 1 & 0 & 1 & 0 & 1 \\ 1003.9 & 0 & -32.2 & 0 & 0 & 0 & 0 \\ 0 & -920 & 0 & 520 & 136.3 & -120 & 0 \\ -160.3 & 0 & 0 & 0 & 0 & 0 & 0 \end{bmatrix}.$$

- (d) Using either `FKinSpace` or `FKinBody`, we find that the transformation from the base to the end-effector at this configuration is

$$T = \begin{bmatrix} 0 & 1 & 0 & 483.87 \\ 1 & 0 & 0 & 160.3 \\ 0 & 0 & -1 & -203 \\ 0 & 0 & 0 & 1 \end{bmatrix}.$$

Solution 4.4

- (a) Given that there are 6 revolute joints, the model would theoretically have 6 degrees of freedom. However, as mentioned in the question, the actual robot arm has joints that are constrained to move together in certain ways.
- (b)

$$M = \begin{bmatrix} 1 & 0 & 0 & 10 \\ 0 & 1 & 0 & 0 \\ 0 & 0 & 1 & 90 \\ 0 & 0 & 0 & 1 \end{bmatrix}.$$

- (c) First, we need to derive the screw axes for each of the revolute joints. The space-frame axis list is:

$$\mathcal{S}_{\text{list}} = \begin{bmatrix} 0 & 0 & 1 & -1 & -1 & 0 \\ 0 & 0 & 0 & 0 & 0 & 0 \\ 1 & 1 & 0 & 0 & 0 & 1 \\ 0 & 0 & 0 & 0 & 0 & 0 \\ 0 & -12 & 45 & -75 & -50 & -10 \\ 0 & 0 & 0 & 0 & 0 & 0 \end{bmatrix}$$

This, along with the M matrix and provided joint angles, can be fed into `FKinSpace`, which returns that the transformation matrix to the end-effector in this case is

$$T = \begin{bmatrix} .7071 & -.7071 & 0 & 23 \\ -.7071 & -.7071 & 0 & -14 \\ 0 & 0 & -1 & 17 \\ 0 & 0 & 0 & 1 \end{bmatrix}.$$

Chapter 5

Practice Exercises on Velocity Kinematics and Statics

5.1 Practice Exercises

Practice exercise 5.1 Figure 4.1 shows the KUKA LBR iiwa 7R robot arm. The figure defines an $\{s\}$ frame at the base with the \hat{y}_s -axis pointing out of the page and a $\{b\}$ frame aligned with $\{s\}$ at the end-effector. The robot is at its home configuration. The screw axes for the seven joints are illustrated (positive rotation about these axes is by the right-hand rule). The axes for joints 2, 4, and 6 are aligned, and the axes for joints 1, 3, 5, and 7 are identical at the home configuration. The dimensions are $L_1 = 0.34$ m, $L_2 = 0.4$ m, $L_3 = 0.4$ m, and $L_4 = 0.15$ m.

- What is the space Jacobian when the robot is at its home configuration?
- What is the body Jacobian when the robot is at its home configuration?
- What is the rank of the space and body Jacobian at the home configuration? (It is always the same.) Is the home configuration a singularity? What is the dimension of the space of feasible twists at the home configuration?

For the remaining questions, assume the angles of the joints are $i\pi/16$ for joints $i = 1 \dots 7$.

- What is the space Jacobian? What joint torques are needed to generate

the wrench $\mathcal{F}_s = (1 \text{ Nm}, 1 \text{ Nm}, 1 \text{ Nm}, 1 \text{ N}, 1 \text{ N}, 1 \text{ N})$? What is the manipulability measure μ_2 for the angular velocity manipulability ellipsoid in the space frame? What is the manipulability measure μ_2 for the linear manipulability ellipsoid in the space frame?

- (e) What is the body Jacobian? What joint torques are needed to generate the wrench $\mathcal{F}_b = (1 \text{ Nm}, 1 \text{ Nm}, 1 \text{ Nm}, 1 \text{ N}, 1 \text{ N}, 1 \text{ N})$? What is the manipulability measure μ_2 for the angular velocity manipulability ellipsoid in the body frame? What is the manipulability measure μ_2 for the linear manipulability ellipsoid in the body frame?

Practice exercise 5.2 Consider a robot with eight joints moving in space. The configuration of the end-effector is represented as an element of $SE(3)$, the velocity of the end-effector is represented as a twist $\mathcal{V} \in \mathbb{R}^6$, and the force and moment at the end-effector is represented as a wrench $\mathcal{F} \in \mathbb{R}^6$. At some joint configurations of the robot, the Jacobian has rank 6; at other configurations, the rank of the Jacobian is lower. Consider a particular joint configuration θ where the rank of the Jacobian is k .

- (a) In the 8-dimensional space of joint velocities $\dot{\theta}$, what is the dimension of the subspace of joint velocities that produce zero twist ($\mathcal{V} = 0$, no motion) of the end-effector?
- (b) In the 6-dimensional space of wrenches \mathcal{F} applied to the end-effector, what is the dimension of the subspace of wrenches that the robot can resist with a zero joint force-torque vector, $\tau = 0$?

In the remaining questions, assume that $1 < k < 6$.

- (c) Assume the task is to position the end-effector in $SE(3)$. Is the robot redundant, kinematically deficient, or neither with respect to this task?
- (d) Is the longest axis of the manipulability ellipsoid zero, infinite, or other?
- (e) Is the shortest axis of the manipulability ellipsoid zero, infinite, or other?
- (f) Is the longest axis of the force ellipsoid zero, infinite, or other?
- (g) Is the shortest axis of the force ellipsoid zero, infinite, or other?

Practice exercise 5.3 Figure 5.1 shows an RPR robot that is confined to the plane of the page. An end-effector frame $\{b\}$ is illustrated, where the \hat{x}_b -axis is out of the page. The directions of positive motion of the three joints are indicated by arrows. The axes of the two revolute joints are out of the page, and the prismatic joint moves in the plane of the page. Joint 1 is at $q_1 = (0, -5, -7)$ in $\{b\}$ and joint 3 is at $q_3 = (0, -1, -3)$ in $\{b\}$. Write the body Jacobian $J_b(\theta)$ for the configuration shown. All entries of your $J_b(\theta)$ matrix should be numerical (no symbols or math).

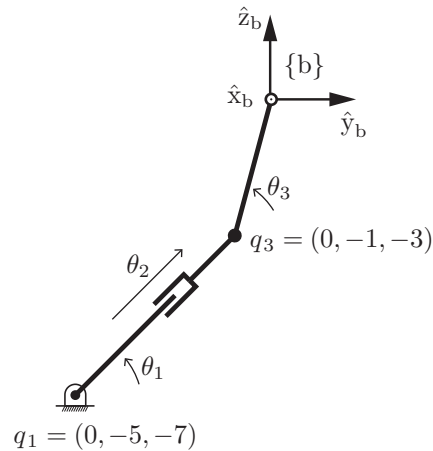

Figure 5.1: An RPR robot.

Practice exercise 5.4 Figure 5.2 shows a simplified pick-and-place robotic arm at its home configuration. Let's apply velocity kinematics and statics to this arm.

- Find $M = T_{sb}(0)$, the configuration of $\{b\}$ relative to $\{s\}$ when the robot is at its zero (home) configuration.
- Find the space-frame screw axis for each joint when the robot is at its home configuration.
- Use the MR library to calculate the body Jacobian at the home configuration using the results from the previous two questions. No need to look at Figure 5.2 again (but you can do so to verify your answers).
- To resist a wrench $\mathcal{F}_s = (0, 0, 0, 5, 10, 0)$ (linear components are in Newtons) applied to the last link of the robot when the robot is at the home configuration, what torques τ must be generated by the joints?
- Use the MR library to find $J_s(\theta)$ at $\theta = (10, \pi/4, -\pi/4, 2, 2, 0)$.

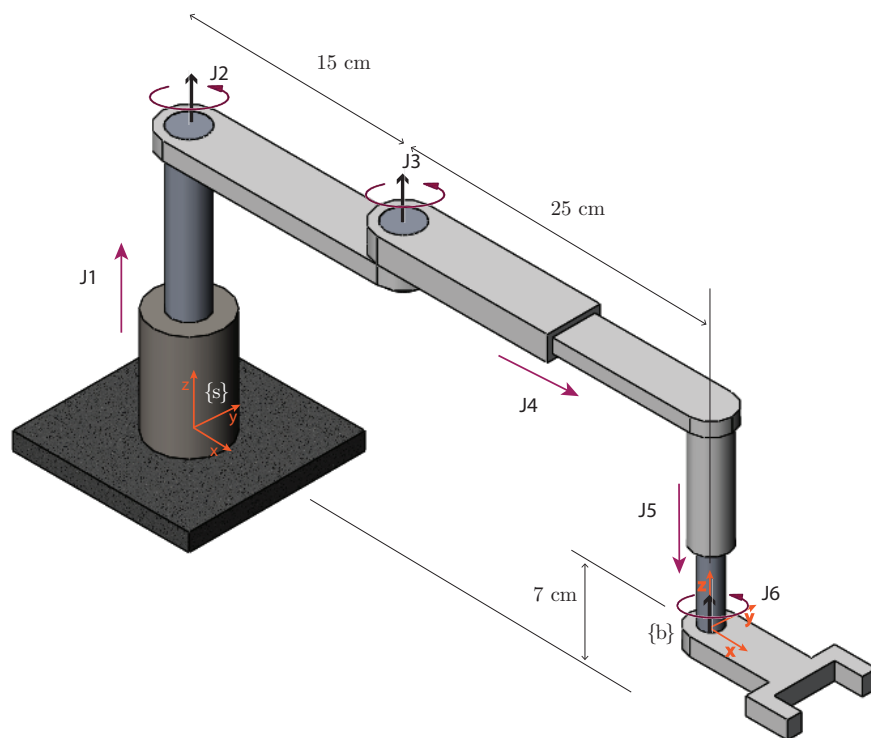

Figure 5.2: A pick-and-place robot shown in its home configuration. The end-effector $\{b\}$ frame is aligned with the $\{s\}$ frame and is 7 cm above the $\{s\}$ frame (in the $+\hat{z}_s$ direction).

5.2 Solutions

Solution 5.1 Angular units are radians and linear units are mm.

(a)

$$J_s = \begin{bmatrix} 0 & 1 & 0 & 1 & 0 & 1 & 0 \\ 0 & 0 & 0 & 0 & 0 & 0 & 0 \\ 1 & 0 & 1 & 0 & 1 & 0 & 1 \\ 0 & 0 & 0 & 0 & 0 & 0 & 0 \\ 0 & 0.34 & 0 & 0.74 & 0 & 1.14 & 0 \\ 0 & 0 & 0 & 0 & 0 & 0 & 0 \end{bmatrix}.$$

(b)

$$J_b = \begin{bmatrix} 0 & 1 & 0 & 1 & 0 & 1 & 0 \\ 0 & 0 & 0 & 0 & 0 & 0 & 0 \\ 1 & 0 & 1 & 0 & 1 & 0 & 1 \\ 0 & 0 & 0 & 0 & 0 & 0 & 0 \\ 0 & -0.95 & 0 & -0.55 & 0 & -0.15 & 0 \\ 0 & 0 & 0 & 0 & 0 & 0 & 0 \end{bmatrix}.$$

(c) The rank is three. Columns 2, 3, and 4 of the Jacobians are linearly independent; all feasible velocity directions are linear combinations of these three columns. The space of feasible twists is three dimensional.

(d) Calculate $J_s(\theta)$ using `JacobianSpace`.

$$\tau = J_s^T(\theta)\mathcal{F}_s = [1 \ 1.44 \ 0.78 \ 1.72 \ 1.13 \ 0.54 \ 2.29]^T.$$

$$\mu_2(J_{s\omega}J_{s\omega}^T) = 2.427, \quad \mu_2(J_{sv}J_{sv}^T) = 30.5.$$

(e) Calculate $J_b(\theta)$ using `JacobianBody`.

$$\tau = J_b^T(\theta)\mathcal{F}_b = [-0.19 \ 1.76 \ 0.18 \ 0.26 \ 1.36 \ -0.96 \ 1]^T.$$

$$\mu_2(J_{b\omega}J_{b\omega}^T) = 2.427, \quad \mu_2(J_{bv}J_{bv}^T) = 20.6.$$

Solution 5.2

(a) $\mathcal{V} = J\dot{\theta}$. This question is asking for the dimension of the null space of J , i.e., the dimension of the subspace of joint velocities $\dot{\theta}$ such that $J\dot{\theta} = 0$. This is also called the nullity of J . J is rank $k \leq 6$, so \mathcal{V} is confined to a k -dimensional linear space, regardless of $\dot{\theta}$. So only k directions in the $\dot{\theta}$ space (\mathbb{R}^8) affect \mathcal{V} , while the other $8 - k$ directions, the null space of

J , have no affect on \mathcal{V} . So an $(8 - k)$ -dimensional space of joint velocities produce zero motion of the end-effector.

Other ways to see this: $J\dot{\theta} = 0$ places k independent constraints on the eight variables of $\dot{\theta}$, so the subspace satisfying these constraints must be $(8 - k)$ -dimensional. Also, the rank-nullity theorem tells us that the sum of the rank of J plus the nullity of J must equal the number of columns of J , so the nullity must be $8 - k$.

- (b) This question is asking for the nullity of J^T in $\tau = J^T \mathcal{F}$. We know that $\text{rank}(J) = \text{rank}(J^T)$, so the rank of J^T is k . By the rank-nullity theorem, $k + \text{nullity}(J^T) = 6$, so $\text{nullity}(J^T) = 6 - k$.
- (c) The robot is redundant, since the Jacobian has a rank of 6 at some configurations (capable of moving in any direction in $SE(3)$) but has eight joints. The terms “redundant” and “kinematically deficient” are independent of the particular configuration, while singularities depend on the configuration.
- (d) Other.
- (e) Zero.
- (f) Infinite.
- (g) Other.

Solution 5.3

$$J_b = \begin{bmatrix} 1 & 0 & 1 \\ 0 & 0 & 0 \\ 0 & 0 & 0 \\ 0 & 0 & 0 \\ -7 & 1/\sqrt{2} & -3 \\ 5 & 1/\sqrt{2} & 1 \end{bmatrix}.$$

You can see this by visualization (imagine turntables at joints 1 and 3 and visualize the motion of a point at the origin of $\{b\}$, and imagine a conveyor moving in the direction of joint 2) or by recognizing that $\omega_1 = \omega_3 = (1, 0, 0)$ and points on the joint 1 and 3 axes are q_1 and q_3 and calculating $v_i = -\omega_i \times q_i$. For joint 2, the linear direction of positive motion is given by $v_2 = (q_3 - q_1) / \|q_3 - q_1\|$.

Solution 5.4

Linear dimensions have been converted to meters.

(a)

$$M = T_{sb}(0) = \begin{bmatrix} 1 & 0 & 0 & 0.40 \\ 0 & 1 & 0 & 0 \\ 0 & 0 & 0 & 0.07 \\ 0 & 0 & 0 & 1 \end{bmatrix}.$$

- (b) The space-frame screw axes of the joints when the robot is at its home configuration are the columns of the space Jacobian $J_s(\theta)$ when $\theta = 0$.

$$\mathcal{S}_{\text{list}} = J_s(0) = \begin{bmatrix} 0 & 0 & 0 & 0 & 0 & 0 \\ 0 & 0 & 0 & 0 & 0 & 0 \\ 0 & 1 & 1 & 0 & 0 & 1 \\ 0 & 0 & 0 & 1 & 0 & 0 \\ 0 & 0 & -0.15 & 0 & 0 & -0.40 \\ 1 & 0 & 0 & 0 & -1 & 0 \end{bmatrix}.$$

- (c) The columns of the Jacobian $J_b(0)$ are the screw axes in the end-effector frame $\{b\}$.

$$J_b(0) = [\text{Ad}_{T_{bs}(0)}]J_s(0) = [\text{Ad}_{M^{-1}}]\mathcal{S}_{\text{list}} = \begin{bmatrix} 0 & 0 & 0 & 0 & 0 & 0 \\ 0 & 0 & 0 & 0 & 0 & 0 \\ 0 & 1 & 1 & 0 & 0 & 1 \\ 0 & 0 & 0 & 1 & 0 & 0 \\ 0 & 0.4 & 0.25 & 0 & 0 & 0 \\ 1 & 0 & 0 & 0 & -1 & 0 \end{bmatrix}.$$

- (d)

$$\tau = -J_s^T(0)\mathcal{F}_s = [0 \quad 0 \quad 1.5 \quad -5 \quad 0 \quad 4]^T.$$

- (e) Use `JacobianSpace`.

$$J_s(\theta) = \begin{bmatrix} 0 & 0 & 0 & 0 & 0 & 0 \\ 0 & 0 & 0 & 0 & 0 & 0 \\ 0 & 1 & 1 & 0 & 0 & 1 \\ 0 & 0 & 0.11 & 1 & 0 & 0.11 \\ 0 & 0 & -0.11 & 0 & 0 & -2.36 \\ 1 & 0 & 0 & 0 & -1 & 0 \end{bmatrix}.$$

Chapter 6

Practice Exercises on Inverse Kinematics

6.1 Practice Exercises

Practice exercise 6.1 Perform three iterations of (approximate) iterative Newton-Raphson root finding on the scalar function $x_d - f(\theta)$ in Figure 6.1, starting from θ^0 . (A general vector function $f(\theta)$ could represent the forward kinematics of a robot, and x_d could represent the desired configuration in coordinates. The roots of $x_d - f(\theta)$ are the joint vectors θ satisfying $x_d - f(\theta) = 0$, i.e., solutions to the inverse kinematics problem.) Draw the iterates θ^1 , θ^2 , and θ^3 on the θ axis and illustrate clearly how you obtain these points.

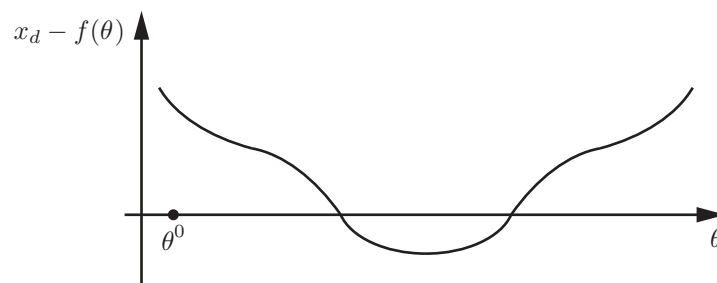

Figure 6.1: A scalar function $x_d - f(\theta)$ of θ .

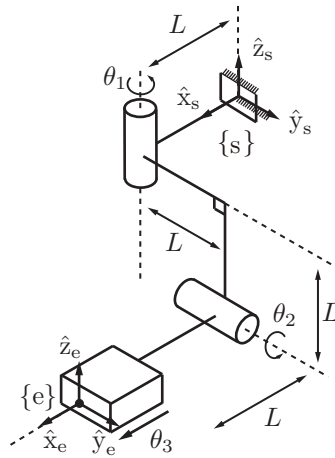

Figure 6.2: An RRP robot.

Practice exercise 6.2 The spatial RRP open chain of Figure 6.2 is shown in its zero position.

- (a) Use analytic methods to solve the inverse kinematics when the end-effector configuration is described by

$$T = \begin{bmatrix} 0 & 1 & 0 & 2L \\ 0 & 0 & -1 & 0 \\ -1 & 0 & 0 & -3L \\ 0 & 0 & 0 & 1 \end{bmatrix}.$$

- (b) Assume that $L = 1$ and use a numerical method (e.g., from the MR code library) to solve the same problem as in (a).

Practice exercise 6.3 Figure 6.3(a) shows the world's first robot system that learns to dress elderly and physically disabled people. The system consists of two 7R WAM robots, whose kinematics are given in Chapter 4.1.3 of the textbook. The overview of the system is shown in Figure 6.3(b). The WAM robots are mounted symmetrically. Suppose the world frame is set as shown in the figure and $D_x = D_z = 0.3$ m. The task is to move one of the robot end-effector frames

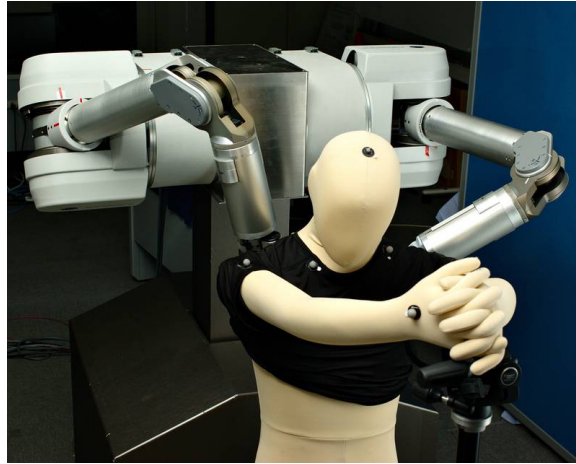

(a) The dressing-assistant robot system.

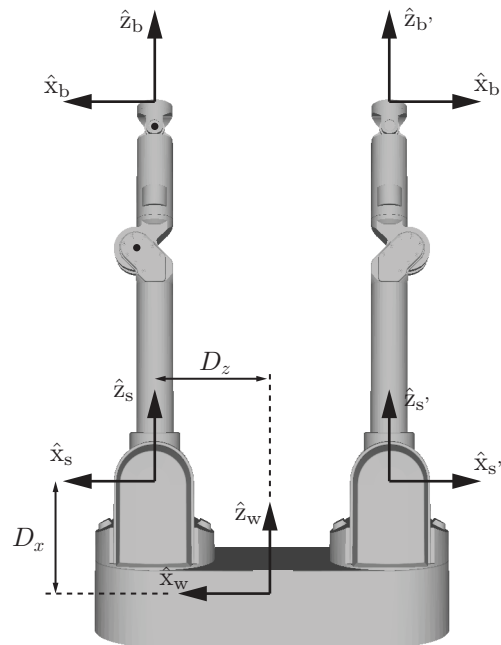

(b) Frames for the two WAM robot arms.

Figure 6.3: The dressing assistant consisting of two WAM robot arms.

to the configuration

$$T = \begin{bmatrix} 0 & 0 & 1 & 0.15 \\ 0 & -1 & 0 & 0 \\ 1 & 0 & 0 & 0.3 \\ 0 & 0 & 0 & 1 \end{bmatrix},$$

relative to $\{w\}$, to hold the clothes. Use the MR code library to solve the following questions. (Ignore joint limits.)

- (a) If one of the robot arms can achieve the configuration, would you generally expect there to be one solution to the inverse kinematics, a finite number of solutions, or an infinite number of solutions?
- (b) Can the left arm achieve the configuration? You could use numerical inverse kinematics with different initial guesses, if needed. If you find a solution, use forward kinematics to verify it. If you cannot find a solution, explain the reason.
- (c) Can the right arm achieve the configuration? You could use numerical inverse kinematics with different initial guesses, if needed. If you find a solution, use forward kinematics to verify it. If you cannot find a solution, explain the reason.

6.2 Solutions

Solution 6.1

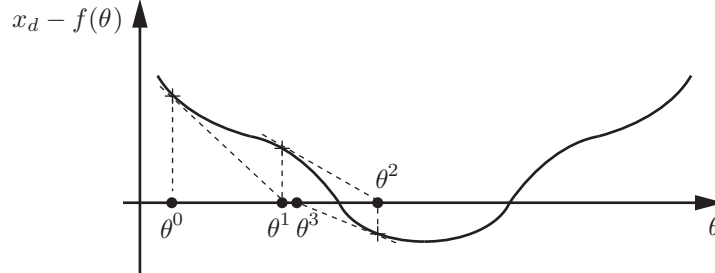

Solution 6.2

- (a) By inspection the first joint rotates along its axis parallel to \hat{z}_s -axis, while the rotation axis of the second joint can move in a plane parallel to $\hat{x}_s - \hat{y}_s$ plane. The orientation of the end-effector can be achieved from the initial orientation by first rotating about the \hat{z}_s -axis for $-\pi/2$ rad and then rotating about the \hat{x}_s -axis for $\pi/2$ rad. So we know that to reach the final end-effector configuration, $\theta_1 = -\pi/2$ and $\theta_2 = \pi/2$. By checking the translation we find $\theta_3 = L$. So the joint angles should be $\theta = (-\pi/2, \pi/2, L)$.
- (b) Use the MR code library (e.g., `IKinBody`), to find the same result, beginning from an initial guess away from the solution.

Solution 6.3

- (a) You would expect an infinite number of solutions, since the robot is redundant (it has 7 dof).
- (b) The configuration is outside the left robot's workspace, so there is no solution.
- (c) Considering the inverse kinematics in the body frame of the right arm, you would get

$$J_b = \begin{bmatrix} 0 & 0 & 0 & 0 & 0 & 0 & 0 \\ 0 & 1 & 0 & 1 & 0 & 1 & 0 \\ 1 & 0 & 1 & 0 & 1 & 0 & 1 \\ 0 & 0.91 & 0 & 0.36 & 0 & 0.06 & 0 \\ 0 & 0 & 0 & 0 & 0 & 0 & 0 \\ 0 & 0 & 0 & 0.045 & 0 & 0 & 0 \end{bmatrix}$$

and

$$M = \begin{bmatrix} -1 & 0 & 0 & -0.3 \\ 0 & -1 & 0 & 0 \\ 0 & 0 & 1 & 1.21 \\ 0 & 0 & 0 & 1 \end{bmatrix}.$$

One example solution, found using `IKinBody`, is

$$\theta = (0, -2.2130, 0, 2.6198, 0, -1.9776, 0).$$

Chapter 7

Practice Exercises on Kinematics of Closed Chains

7.1 Practice Exercises

7.2 Solutions

Chapter 8

Practice Exercises on Dynamics of Open Chains

8.1 Practice Exercises

Practice exercise 8.1 Figure 8.1 illustrates an RP robot moving in a vertical plane. The mass of link 1 is m_1 and the center of mass is a distance L_1 from joint 1. The scalar inertia of link 1 about an axis through the center of mass and out of the plane is \mathcal{I}_1 . The mass of link 2 is m_2 , the center of mass is a distance θ_2 from joint 1, and the scalar inertia of link 2 about its center of mass is \mathcal{I}_2 . Gravity g acts downward on the page.

- Let the location of the center of mass of link i be (x_i, y_i) . Find (x_i, y_i) for $i = 1, 2$, and their time derivatives, in terms of θ and $\dot{\theta}$.
- Write the potential energy of each of the two links, \mathcal{P}_1 and \mathcal{P}_2 , using the

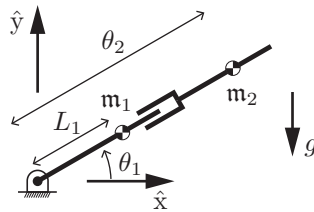

Figure 8.1: An RP robot operating in a vertical plane.

joint variables θ .

- (c) Write the kinetic energy of each of the two links, \mathcal{K}_1 and \mathcal{K}_2 . (Recall that the kinetic energy of a rigid body moving in the plane is $\mathcal{K} = (1/2)\mathbf{m}v^2 + (1/2)\mathcal{I}\omega^2$, where \mathbf{m} is the mass, v is the scalar linear velocity at the center of mass, ω is the scalar angular velocity, and \mathcal{I} is the scalar inertia of the rigid body about its center of mass.)
- (d) What is the Lagrangian in terms of \mathcal{K}_1 , \mathcal{K}_2 , \mathcal{P}_1 , and \mathcal{P}_2 ?
- (e) One of the terms in the Lagrangian can be expressed as

$$\frac{1}{2}\mathbf{m}_2\theta_2^2\dot{\theta}_1^2.$$

If this were the complete Lagrangian, what would the equations of motion be? Derive these by hand (no symbolic math software assistance). Indicate which of the terms in your equations are a function of $\ddot{\theta}$, which are Coriolis terms, which are centripetal terms, and which are gravity terms, if any.

- (f) Now derive the equations of motion (either by hand or using symbolic math software for assistance) for the full Lagrangian and put them in the form

$$\tau = M(\theta)\ddot{\theta} + c(\theta, \dot{\theta}) + g(\theta).$$

Identify which of the terms in $c(\theta, \dot{\theta})$ are Coriolis and which are centripetal. Explain as if to someone who is unfamiliar with dynamics why these terms contribute to the joint forces and torques.

- (g) Consider the configuration-dependent mass matrix $M(\theta)$ from your previous answer. When the robot is at rest (and ignoring gravity), the mass matrix can be visualized as the ellipse of joint forces/torques that are required to generate the unit circle of joint accelerations in $\ddot{\theta}$ space. As θ_2 increases, how does this ellipse change? Describe it in text and provide a drawing.
- (h) Now visualize the configuration-dependent end-effector mass matrix $\Lambda(\theta)$, where the “end-effector” is considered to be at the point (x_2, y_2) , the location of the center of mass of the second link. For a unit circle of accelerations (\ddot{x}_2, \ddot{y}_2) , consider the ellipse of linear forces that are required to be applied at the end-effector to realize these accelerations. How does the orientation of this ellipse change as θ_1 changes? How does the shape change as θ_2 increases from zero to infinity when $\theta_1 = 0$? Provide a drawing for the case $\theta_1 = 0$. If you have access to symbolic computation software (e.g., Mathematica), you can use the Jacobian $J(\theta)$ satisfying

$$\begin{bmatrix} \dot{x}_2 \\ \dot{y}_2 \end{bmatrix} = J(\theta)\dot{\theta}$$

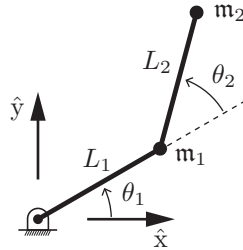

Figure 8.2: A 2R robot with all mass concentrated at the ends of the links.

to calculate $\Lambda(\theta) = J^{-T}(\theta)M(\theta)J^{-1}(\theta)$ for the case $\theta_1 = 0$. If you do not have access to symbolic computation software, you can plug in numerical values for L_1 , L_2 , m_1 , m_2 , and L_1 (make them all equal to 1, for example) to say something about how Λ changes (and therefore how the ellipse changes) as θ_2 goes from zero to infinity while $\theta_1 = 0$.

Practice exercise 8.2 The mass matrix of the 2R robot of Figure 8.2 is

$$M(\theta) = \begin{bmatrix} m_1 L_1^2 + m_2(L_1^2 + 2L_1 L_2 \cos \theta_2 + L_2^2) & m_2(L_1 L_2 \cos \theta_2 + L_2^2) \\ m_2(L_1 L_2 \cos \theta_2 + L_2^2) & m_2 L_2^2 \end{bmatrix},$$

where each link is modeled as a point mass at the end of the link. Explain in text and/or figures why each of the entries makes sense, for example using the joint accelerations $\ddot{\theta} = (1, 0)$ and $(0, 1)$.

Practice exercise 8.3 The equations of motion for a particular 2R robot arm can be written $M(\theta)\ddot{\theta} + c(\theta, \dot{\theta}) + g(\theta) = \tau$. The Lagrangian $\mathcal{L}(\theta, \dot{\theta})$ for the robot can be written in components as

$$\mathcal{L}(\theta, \dot{\theta}) = \mathcal{L}^1(\theta, \dot{\theta}) + \mathcal{L}^2(\theta, \dot{\theta}) + \mathcal{L}^3(\theta, \dot{\theta}) + \dots$$

One of these components is $\mathcal{L}^1 = m\dot{\theta}_1\dot{\theta}_2 \cos \theta_2$.

- Find the joint torques τ_1 and τ_2 corresponding to the component \mathcal{L}^1 .
- Write the 2×2 mass matrix $M^1(\theta)$, the velocity-product vector $c^1(\theta, \dot{\theta})$, and the gravity vector $g^1(\theta)$ corresponding to \mathcal{L}^1 . (Note that $M = M^1 + M^2 + M^3 + \dots$, $c = c^1 + c^2 + c^3 + \dots$, and $g = g^1 + g^2 + g^3 + \dots$)

Practice exercise 8.4 For a given configuration θ of a two-joint robot, the mass matrix is

$$M(\theta) = \begin{bmatrix} 3 & a \\ b & 2 \end{bmatrix},$$

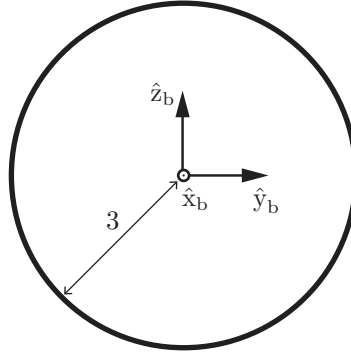

Figure 8.3: A ring of radius 3.

which has a determinant of $6 - ab$ and eigenvalues $\frac{1}{2}(5 \pm \sqrt{1 + 4ab})$. What constraints must a and b satisfy for this to be a valid mass matrix?

Practice exercise 8.5 Link i of an open-chain robot has two frames attached to it, a frame $\{b\}$ at its center of mass and a frame $\{a\}$ on the axis of joint i , a revolute joint, that drives the link. In the frame $\{a\}$, the screw axis of the revolute joint is expressed as \mathcal{S} . In the backward iterations of Newton-Euler inverse dynamics, it was determined that the wrench \mathcal{F}_b (expressed in $\{b\}$) must be applied to the link. What joint torque τ_i must be applied at joint i , in terms of \mathcal{F}_b , \mathcal{S} , and the frames $\{a\}$ and $\{b\}$?

Practice exercise 8.6 Figure 8.3 shows a ring in the \hat{y}_b - \hat{z}_b plane (the \hat{x}_b coordinate of each point on the ring is zero). The radius of the ring is 3 (all mass is a distance 3 from the \hat{x}_b -axis). The mass of the ring is 10, and the mass is uniformly distributed around the ring. Write the spatial inertia matrix \mathcal{G}_b . All entries should be numerical, no symbols or math.

Practice exercise 8.7 The Lagrangian of a particular two-joint robot is

$$\mathcal{L} = \mathcal{L}^1 + \text{other terms}$$

where

$$\mathcal{L}^1 = \dot{\theta}_1 \dot{\theta}_2 + \dot{\theta}_2^2 \cos \theta_2.$$

- (a) Find τ_1^1 , the force/torque at joint 1 (for arbitrary θ , $\dot{\theta}$, $\ddot{\theta}$) due to \mathcal{L}^1 . For each term in your answer, label it as a mass matrix term, a Coriolis term, a centripetal term, or a gravity term.

- (b) Find τ_2^1 , the force/torque at joint 2 (for arbitrary $\theta, \dot{\theta}, \ddot{\theta}$) due to \mathcal{L}^1 . For each term in your answer, label it as a mass matrix term, a Coriolis term, a centripetal term, or a gravity term.

Practice exercise 8.8 Consider the four equivalent forms of dynamics shown below:

$$\tau = M(\theta)\ddot{\theta} + h(\theta, \dot{\theta}) + J^T(\theta)\mathcal{F}_{\text{tip}}, \quad (8.1)$$

$$\tau = M(\theta)\ddot{\theta} + c(\theta, \dot{\theta}) + g(\theta) + J^T(\theta)\mathcal{F}_{\text{tip}}, \quad (8.2)$$

$$\tau = M(\theta)\ddot{\theta} + C(\theta, \dot{\theta})\dot{\theta} + g(\theta) + J^T(\theta)\mathcal{F}_{\text{tip}}, \quad (8.3)$$

$$\tau = M(\theta)\ddot{\theta} + \dot{\theta}^T \Gamma(\theta) \dot{\theta} + g(\theta) + J^T(\theta)\mathcal{F}_{\text{tip}}, \quad (8.4)$$

- (a) List the variables common to all of the equations, what they represent, their dimension, how they are derived, and any constraints they must always follow or properties they must satisfy.
- (b) For the unique variables in each of the equations, describe what they represent and provide the dimension.

Practice exercise 8.9 Consider the quadcopter and attached pendulum shown in Figure 8.4. The rod is attached to the quadcopter by a revolute joint, and you are given the task of balancing the rod upright (a flying version of the classic cart pendulum problem). Assume the configuration of the quadcopter center is described by (x_q, y_q, θ_q) and the configuration of the rod center is described as (x_r, y_r, θ_r) where θ_q and θ_r are measured with respect to the world x axis. The length of the rod is $2l$, the masses are m_q , and m_r , and the rotational inertias are I_q and I_r .

Solve for the kinetic and potential energy terms and the Lagrangian for the generalized coordinates $(x_q, y_q, \theta_q, \theta_r)$.

Practice exercise 8.10 Consider the object in Figure 8.5 that consists of a cube and sphere that are rigidly attached. The {c} and {s} frames of each component are aligned with the principal axes and located at the center of mass. The z -axes of both frames are colinear. Given that the body inertia of a sphere is $\mathcal{I}_s = (2mr^2/5 * I^{3 \times 3})$, the body inertia of a cube is $\mathcal{I}_c = ml^2/6 * I^{3 \times 3}$, $r = 1$, $l = 2$, the cube has mass 2, and the sphere has mass 1, solve for the spatial inertia matrix \mathcal{G}_b for the object.

Practice exercise 8.11 You are teaching Newton-Euler inverse dynamics, and you are using the 2R robot from the beginning of Chapter 8 (see also

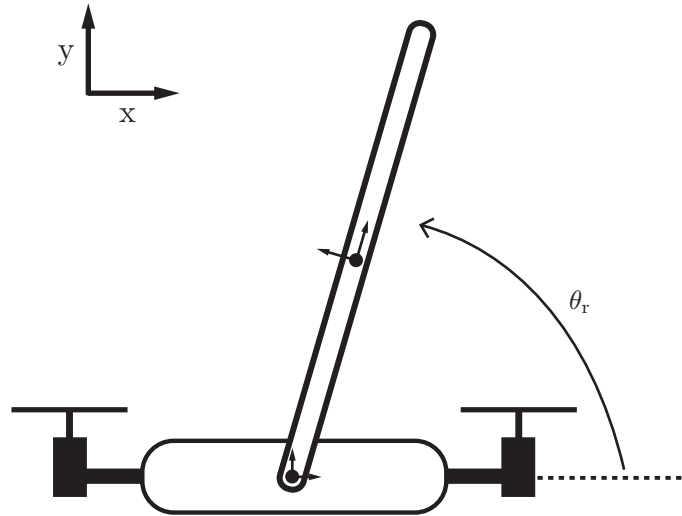

Figure 8.4: 2D quadcopter and attached pendulum.

Figure 8.6) as an example. Each link has length L_i and the mass of each link is m_i , concentrated at a point at the end of the link. You already know the correct dynamics from the Lagrangian derivation. Now you will show how to arrive at the same answer using Newton-Euler. Go through the method step by step, showing intermediate results if it is helpful.

- Give \mathcal{M}_i , $\mathcal{M}_{i-1,i}$, \mathcal{A}_i , \mathcal{S}_i , \mathbf{g} , \mathcal{G}_i , \mathcal{V}_0 , $\dot{\mathcal{V}}_0$. You can assume the frame $\{3\}$ is coincident with $\{2\}$ and \mathcal{F}_{tip} is zero.
- Forward Iteration: First calculate the transformation, twist, and twist derivative for link 1, then calculate them for link 2.
- Backward Iteration: First calculate \mathcal{F}_2 and τ_2 , then calculate \mathcal{F}_1 and τ_1 . Confirm that your final result agrees with the result in the notes.

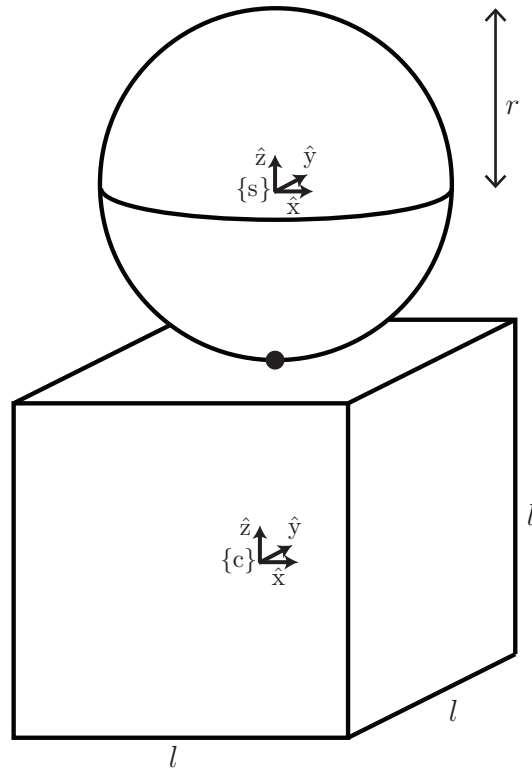

Figure 8.5: Rigid object consisting of a sphere and cube.

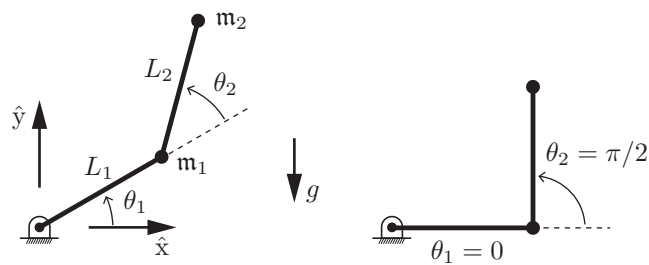

Figure 8.6: 2R robot.

8.2 Solutions

Solution 8.1

(a)

$$\begin{aligned} x_1 &= L_1 \cos \theta_1 & \dot{x}_1 &= -L_1 \dot{\theta}_1 \sin \theta_1 \\ x_2 &= \theta_2 \cos \theta_1 & \dot{x}_2 &= \dot{\theta}_2 \cos \theta_1 - \theta_2 \dot{\theta}_1 \sin \theta_1 \\ y_1 &= L_1 \sin \theta_1 & \dot{y}_1 &= L_1 \dot{\theta}_1 \cos \theta_1 \\ y_2 &= \theta_2 \sin \theta_1 & \dot{y}_2 &= \dot{\theta}_2 \sin \theta_1 + \theta_2 \dot{\theta}_1 \cos \theta_1. \end{aligned}$$

(b)

$$\begin{aligned} \mathcal{P}_1 &= \mathbf{m}_1 g y_1 = \mathbf{m}_1 g L_1 \sin \theta_1 \\ \mathcal{P}_2 &= \mathbf{m}_2 g y_2 = \mathbf{m}_2 g \theta_2 \sin \theta_1. \end{aligned}$$

(c)

$$\begin{aligned} \mathcal{K}_1 &= \frac{1}{2} \mathbf{m}_1 (\dot{x}_1^2 + \dot{y}_1^2) + \frac{1}{2} \mathcal{I}_1 \dot{\theta}_1^2 = \frac{1}{2} (\mathcal{I}_1 + \mathbf{m}_1 L_1^2) \dot{\theta}_1^2 \\ \mathcal{K}_2 &= \frac{1}{2} \mathbf{m}_2 (\dot{x}_2^2 + \dot{y}_2^2) + \frac{1}{2} \mathcal{I}_2 \dot{\theta}_2^2 = \frac{1}{2} \left((\mathcal{I}_2 + \mathbf{m}_2 \theta_2^2) \dot{\theta}_1^2 + \mathbf{m}_2 \dot{\theta}_2^2 \right). \end{aligned}$$

(d) $\mathcal{L} = \mathcal{K}_1 + \mathcal{K}_2 - \mathcal{P}_1 - \mathcal{P}_2$.(e) $\tau_1 = 2\mathbf{m}_2 \theta_2 \dot{\theta}_1 \dot{\theta}_2 + \mathbf{m}_2 \theta_2^2 \ddot{\theta}_1$. The first term is a Coriolis term and the second term depends on $\dot{\theta}_1$. $\tau_2 = -\mathbf{m}_2 \theta_2 \dot{\theta}_1^2$. This term is a centripetal term.

(f)

$$M(\theta) = \begin{bmatrix} \mathcal{I}_1 + \mathcal{I}_2 + \mathbf{m}_1 L_1^2 + \mathbf{m}_2 \theta_2^2 & 0 \\ 0 & \mathbf{m}_2 \end{bmatrix}, \quad c(\theta, \dot{\theta}) = \begin{bmatrix} 2\mathbf{m}_2 \theta_2 \dot{\theta}_1 \dot{\theta}_2 \\ -\mathbf{m}_2 \theta_2 \dot{\theta}_1^2 \end{bmatrix},$$

$$g(\theta) = \begin{bmatrix} (\mathbf{m}_1 L_1 + \mathbf{m}_2 \theta_2) g \cos \theta_1 \\ \mathbf{m}_2 g \sin \theta_1 \end{bmatrix}.$$

(g) The mass matrix $M(\theta)$ is diagonal, so the principal axes of the ellipse $M(\theta)\ddot{\theta}$ (for all $\ddot{\theta}$ satisfying $|\ddot{\theta}| = 1$) are aligned with the τ_1 and τ_2 axes, and the lengths of those principal axes (the eigenvalues of M) are just the entries along the diagonal. As θ_2 gets larger, the top left component of M gets larger. This means that larger torques at joint 1 are required to generate accelerations in the $\ddot{\theta}_1$ direction, due to the increased inertia of the robot about joint 1. Hence the ellipse gets wider in the τ_1 direction. See Figure 8.7.

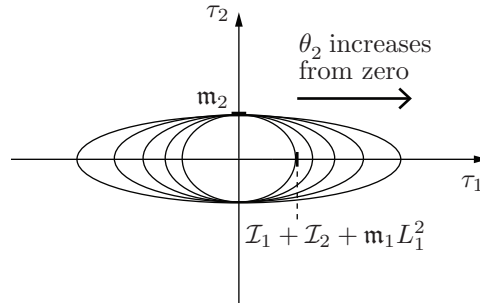

Figure 8.7: The mass matrix $M(\theta)$ represented as the ellipse of joint forces and torques corresponding to a unit circle of joint accelerations $\ddot{\theta}$ (when gravity and the joint velocities are zero).

- (h) The Jacobian relating joint velocities $\dot{\theta}$ to the velocity of the end-effector (\dot{x}_2, \dot{y}_2) is

$$J(\theta) = \begin{bmatrix} -\theta_2 \sin \theta_1 & \cos \theta_1 \\ \theta_2 \cos \theta_1 & \sin \theta_1 \end{bmatrix}$$

and the end-effector mass matrix is

$$\Lambda(\theta) = J^{-T} M J^{-1}.$$

We are interested in the ellipse $\Lambda(\theta)[\ddot{x}_2 \ \ddot{y}_2]^T$ (in the (f_x, f_y) space) when the end-effector acceleration is a unit vector.

The orientation of this ellipse rotates with θ_1 , so we can just consider the case for a particular constant θ_1 , i.e., $\theta_1 = 0$ (the end-effector is at $(x_2, y_2) = (0, \theta_2)$). In this case, a force applied to the end-effector in the f_x direction acts to extend or retract joint 2 while a force in the f_y direction acts to rotate the robot about joint 1.

Evaluating $\Lambda(\theta)$ with $\theta_1 = 0$, we get the diagonal matrix

$$\begin{bmatrix} m_2 & 0 \\ 0 & (\mathcal{I}_1 + \mathcal{I}_2 + m_1 L_1^2 + m_2 \theta_2^2) / \theta_2^2 \end{bmatrix} = \begin{bmatrix} m_2 & 0 \\ 0 & (k + m_2 \theta_2^2) / \theta_2^2 \end{bmatrix},$$

where k is a positive constant. Since the matrix is diagonal, the principal axes of the ellipse $\Lambda(\theta)[\ddot{x}_2 \ \ddot{y}_2]^T$ (where the end-effector acceleration is a unit vector) are aligned with the f_x and f_y axes and the lengths of the principal components are the entries along the diagonal.

The apparent mass at the end-effector in the radial (x) direction is m_2 , i.e., it is independent of θ_2 . The apparent mass in the tangential (y) direction

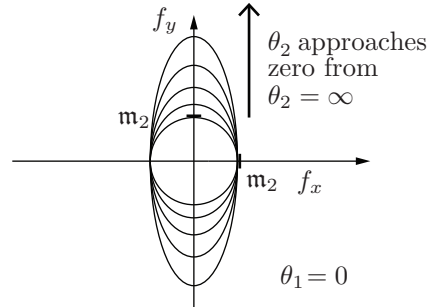

Figure 8.8: The end-effector mass matrix $\Lambda(\theta)$ represented as the ellipse of forces that must be applied to the end-effector to create a circle of accelerations (\ddot{x}_2, \ddot{y}_2) . As θ_2 goes to infinity, the magnitude of the force required to generate a unit acceleration $(0, \ddot{y}_2)$ approaches m_2 , i.e., the robot feels like a point mass with mass m_2 .

depends on θ_2 , however. As θ_2 approaches zero from above, the bottom right component of Λ approaches infinity. This means large f_y forces are needed to accelerate the tip in the y direction. This is because the torque about joint 1 provided by a force f_y through the end-effector tends to zero as the end-effector approaches joint 1, and therefore f_y must become large to generate the angular acceleration of the inertia about joint 1 needed to generate a modest \ddot{y}_2 acceleration. Accordingly, the principal axis of the end-effector mass ellipse in the f_y direction becomes large (Figure 8.8).

As θ_2 approaches infinity, the bottom right element of Λ drops to m_2 , and the end-effector mass matrix ellipse approaches a circle: the end-effector feels like a mass m_2 in every direction.

Solution 8.2 Let

$$M = \begin{bmatrix} M_{11} & M_{12} \\ M_{21} & M_{22} \end{bmatrix},$$

where $M_{11} = m_1 L_1^2 + m_2(L_1^2 + 2L_1 L_2 \cos \theta_2 + L_2^2)$, $M_{12} = M_{21} = m_2(L_1 L_2 \cos \theta_2 + L_2^2)$, and $M_{22} = m_2 L_2^2$.

Figure 8.9 shows the linear accelerations of the masses m_1 and m_2 for joint accelerations $(1, 0)$ and $(0, 1)$.

The terms M_{11} and M_{22} are relatively easy to understand. The term M_{11} is the inertia of the robot about joint 1 if joint 2 is locked. The inertia contribution due to m_1 is $m_1 L_1^2$. The distance of m_2 from joint 1 is $d_2 = \sqrt{L_1^2 + 2L_1 L_2 \cos \theta_2 + L_2^2}$ (by the law of cosines), and the inertia contribution due to m_2 is $m_2 d_2^2$.

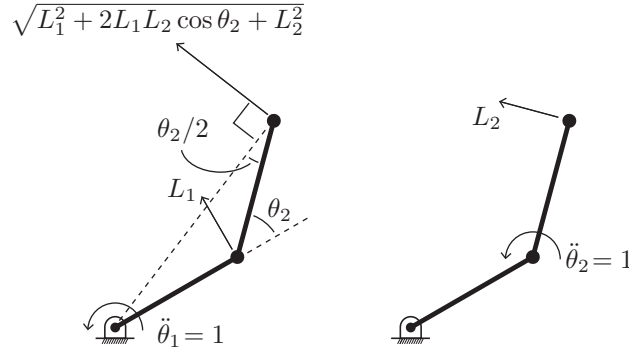

Figure 8.9: The linear accelerations of the point masses of the 2R arm for joint accelerations $(1, 0)$ and $(0, 1)$.

The term M_{22} is the inertia about joint 2 due to the mass \mathbf{m}_2 a distance L_2 from the joint.

The off-diagonal term is harder to understand. But we know that if joint 1 accelerates, joint 2 has to apply a torque to keep joint 2 locked. And if joint 2 accelerates, joint 1 has to apply a torque to remain locked; otherwise, conservation of angular momentum about joint 1 would cause it to begin to rotate in a direction opposite joint 2. Using Figure 8.9 and some geometry, you could calculate the joint torque τ_2 required to keep joint 2 stationary when $\dot{\theta}_1 = 1$, based on the moment about joint 2 generated by the line of force required to accelerate \mathbf{m}_2 .

Solution 8.3

(a)

$$\tau_1 = \frac{d}{dt} \left(\frac{\partial \mathcal{L}^1}{\partial \dot{\theta}_1} \right) - \frac{\partial \mathcal{L}^1}{\partial \theta_1} = \frac{d}{dt} (\mathbf{m} \dot{\theta}_2 \cos \theta_2) - 0 = \mathbf{m} \ddot{\theta}_2 \cos \theta_2 - \mathbf{m} \dot{\theta}_2^2 \sin \theta_2$$

$$\tau_2 = \frac{d}{dt} \left(\frac{\partial \mathcal{L}^1}{\partial \dot{\theta}_2} \right) - \frac{\partial \mathcal{L}^1}{\partial \theta_2} = \frac{d}{dt} (\mathbf{m} \dot{\theta}_1 \cos \theta_2) + \mathbf{m} \dot{\theta}_1 \dot{\theta}_2 \sin \theta_2 = \mathbf{m} \ddot{\theta}_1 \cos \theta_2$$

(b)

$$M^1(\theta) = \begin{bmatrix} 0 & \mathbf{m} \cos \theta_2 \\ \mathbf{m} \cos \theta_2 & 0 \end{bmatrix}, \quad c^1(\theta, \dot{\theta}) = \begin{bmatrix} -\mathbf{m} \dot{\theta}_2^2 \sin \theta_2 \\ 0 \end{bmatrix},$$

$$g^1(\theta) = \begin{bmatrix} 0 \\ 0 \end{bmatrix}.$$

Solution 8.4 $M(\theta)$ must be positive definite (and therefore symmetric), so $a = b$ and the eigenvalues must be positive, so $|a| = |b| < \sqrt{6}$. (The determinant $\det(M) = 6 - a^2$ must be positive, which gives the same condition on $|a|$.)

Solution 8.5 Take the dot product of the wrench with the screw axis after they've been expressed in the same frame, e.g., in the frame $\{b\}$, $\mathcal{F}_b^T [\text{Ad}_{T_{ba}}] \mathcal{S}$.

Solution 8.6

$$\mathcal{G}_b = \begin{bmatrix} 90 & 0 & 0 & 0 & 0 & 0 \\ 0 & 45 & 0 & 0 & 0 & 0 \\ 0 & 0 & 45 & 0 & 0 & 0 \\ 0 & 0 & 0 & 10 & 0 & 0 \\ 0 & 0 & 0 & 0 & 10 & 0 \\ 0 & 0 & 0 & 0 & 0 & 10 \end{bmatrix},$$

where the inertia about the \hat{x}_b -axis is $\mathbf{m}R^2 = 90$ since $\mathbf{m} = 10$ and $R = 3$. The inertia about the \hat{y}_b and \hat{z}_b axes is $(1/2)\mathbf{m}R^2$ (derive this formula from the integral or look it up online).

Solution 8.7

$$\begin{aligned} \text{(a)} \quad \tau_1^1 &= \ddot{\theta}_2 \text{ (mass matrix term).} \\ \text{(b)} \quad \tau_2^1 &= \underbrace{\ddot{\theta}_1 + 2\ddot{\theta}_2 \cos \theta_2}_{\text{mass matrix terms}} - \underbrace{\dot{\theta}_2^2 \sin \theta_2}_{\text{centripetal term}}. \end{aligned}$$

Solution 8.8

- (a) τ : the torque or force at each of the joints represented by the generalized coordinates. Dimensions are $n \times 1$ array.
 $M(\theta)$: the configuration dependent mass matrix. Dimensions are $n \times n$ matrix. M must be symmetric and positive definite.
 θ : The generalized coordinates for the joints. Dimensions are $n \times 1$ array.
 $\dot{\theta}$: The acceleration of the joints represented by the generalized coordinates. Dimensions are $n \times 1$ array.
 $J(\theta)$: The Jacobian (depends on configuration θ). Dimensions are $n \times n$ matrix.
 \mathcal{F}_{tip} : The force applied at the tip of the robot. Dimensions are $n \times 1$ array.
- (b) 8.1: The most general representation, and $h(\theta, \dot{\theta})$ is an $n \times 1$ array that contains the centripetal, coriolis, and gravity terms.

8.2: $c(\theta, \dot{\theta})$ is an $n \times 1$ array that contains the centripetal and coriolis terms, and $g(\theta)$ is an $n \times 1$ array that contains the gravity terms.

8.3: $C(\theta, \dot{\theta})$ is the $n \times n$ Coriolis matrix.

8.4: $\Gamma(\theta)$ is the $n \times n \times n$ Christoffel matrix. Emphasizes that the Coriolis and centripetal (velocity product) terms are quadratic in the velocity and that Γ depends only on θ .

Solution 8.9

The kinetic energy contains the translational kinetic energy of the rod and quadcopter as well as the rotational kinetic energy of both bodies.

Quadcopter translational kinetic energy:

$$v_q^2 = \dot{x}_q^2 + \dot{y}_q^2$$

$$\mathcal{K}_{q,\text{trans}} = \frac{1}{2}m_q(\dot{x}_q^2 + \dot{y}_q^2).$$

Quadcopter rotational kinetic energy:

$$\mathcal{K}_{q,\text{rot}} = \frac{1}{2}I_q\dot{\theta}_q^2.$$

Rod translational kinetic energy:

$$x_r = x_q + l \cos(\theta_r)$$

$$y_r = y_q + l \sin(\theta_r)$$

$$\dot{x}_r = \dot{x}_q - l \sin(\theta_r)\dot{\theta}_r$$

$$\dot{y}_r = \dot{y}_q + l \cos(\theta_r)\dot{\theta}_r$$

$$v_r^2 = \dot{x}_r^2 + \dot{y}_r^2 = (\dot{x}_q - l \sin(\theta_r)\dot{\theta}_r)^2 + (\dot{y}_q + l \cos(\theta_r)\dot{\theta}_r)^2$$

$$\mathcal{K}_{r,\text{trans}} = \frac{1}{2}m_r v_r^2$$

Rod rotational kinetic energy:

$$\mathcal{K}_{r,\text{rot}} = \frac{1}{2}I_r\dot{\theta}_r^2.$$

Total kinetic energy:

$$\mathcal{K} = \mathcal{K}_{q,\text{trans}} + \mathcal{K}_{q,\text{rot}} + \mathcal{K}_{r,\text{trans}} + \mathcal{K}_{r,\text{rot}} = \frac{1}{2}m_q(\dot{x}_q^2 + \dot{y}_q^2) + \frac{1}{2}I_q\dot{\theta}_q^2 + \frac{1}{2}m_r((\dot{x}_q - l \sin(\theta_r)\dot{\theta}_r)^2 + (\dot{y}_q + l \cos(\theta_r)\dot{\theta}_r)^2) + \frac{1}{2}I_r\dot{\theta}_r^2.$$

Potential Energy:

$$\mathcal{P} = \frac{1}{2}m_q y_q + \frac{1}{2}m_r(y_q + l \sin(\theta_r)).$$

$$\text{Lagrangian} = \mathcal{L} = \mathcal{K} - \mathcal{P} = \frac{1}{2}m_q(\dot{x}_q^2 + \dot{y}_q^2) + \frac{1}{2}I_q\dot{\theta}_q^2 + \frac{1}{2}m_r((\dot{x}_q - l \sin(\theta_r)\dot{\theta}_r)^2 + (\dot{y}_q + l \cos(\theta_r)\dot{\theta}_r)^2) + \frac{1}{2}I_r\dot{\theta}_r^2 - \frac{1}{2}m_q y_q + \frac{1}{2}m_r(y_q + l \sin(\theta_r)).$$

Solution 8.10

$$COM_s = (0, 0, 3), \quad COM_c = (0, 0, 1).$$

$$COM_b = (COM_s m_s + COM_c m_c)/2.$$

$$q_c = COM_b - COM_c$$

$$q_s = COM_b - COM_s$$

$$I_1 = I_c + m_c(q_c^T q_c I - q_c q_c^T)$$

$$\begin{aligned}
 I_2 &= I_s + m_s(q_s^T q_s I - q_s q_s^T) \\
 I_b &= I_1 + I_2 = \text{diag}(6.48, 6.48, 1.73) \\
 \mathcal{G}_b &= \text{diag}(6.48, 6.48, 1.73, 3, 3, 3)
 \end{aligned}$$

Solution 8.11

- (a) Observe the drawing. Find the transformation matrix $\mathcal{M}_i \in SE(3)$ for each link. \mathcal{M}_i is the transformation from the base frame $\{0\}$ to the frame $\{i\}$, which is attached to the center of mass of the i -th link, when the robot is in its home configuration.

$$\mathcal{M}_1 = \begin{bmatrix} 1 & 0 & 0 & L_1 \\ 0 & 1 & 0 & 0 \\ 0 & 0 & 1 & 0 \\ 0 & 0 & 0 & 1 \end{bmatrix}, \quad \mathcal{M}_2 = \begin{bmatrix} 1 & 0 & 0 & L_1 + L_2 \\ 0 & 1 & 0 & 0 \\ 0 & 0 & 1 & 0 \\ 0 & 0 & 0 & 1 \end{bmatrix}.$$

$\mathcal{M}_{12} \in SE(3)$ is the transformation matrix from the frame $\{1\}$ (attached to center of mass of link 1) to the frame $\{2\}$ (attached to the center of mass of link 2), when the arm is in its home configuration. Find \mathcal{M}_{12} by observing the drawing or by using the equation $\mathcal{M}_{12} = \mathcal{M}_1^{-1} \mathcal{M}_2$.

$$\mathcal{M}_2 = \begin{bmatrix} 1 & 0 & 0 & L_2 \\ 0 & 1 & 0 & 0 \\ 0 & 0 & 1 & 0 \\ 0 & 0 & 0 & 1 \end{bmatrix}.$$

From observing the drawing, obtain the screw-axis \mathcal{S}_i for each joint, expressed in the space-frame:

$$\mathcal{S}_1 = [0, 0, 1, 0, 0, 0]^T, \quad \mathcal{S}_2 = [0, 0, 1, 0, -L_1, 0]^T.$$

\mathcal{A}_i is the twist-vector for joint i expressed in the frame $\{i\}$ when the arm is in its home configuration ($\theta_i = 0$). For a simple 2R arm it can be obtained by observing the spatial velocity of frame $\{i\}$ when rotating about joint i from the home configuration. Alternatively one may use the equation $\mathcal{A}_i = \text{Ad}_{\mathcal{M}_i^{-1}} \mathcal{S}_i$.

$$\mathcal{A}_1 = [0, 0, 1, 0, L_1, 0]^T, \quad \mathcal{A}_2 = [0, 0, 1, 0, L_2, 0]^T.$$

Define the gravity vector $\mathbf{g} = [0, g, 0]^T$ with $g < 0$. Define the spatial inertia matrix \mathcal{G}_i for each link i , expressed in the frame $\{i\}$. In the case of the 2R robot we assume that the mass is concentrated as a point mass at the end of each link. This is the origin of frame $\{i\}$, so relative to the frame $\{i\}$, the mass of link $\{i\}$ has no rotational inertia.

$$\mathcal{G}_1 = \begin{bmatrix} 0 & 0 & 0 & 0 & 0 & 0 \\ 0 & 0 & 0 & 0 & 0 & 0 \\ 0 & 0 & 0 & 0 & 0 & 0 \\ 0 & 0 & 0 & m_1 & 0 & 0 \\ 0 & 0 & 0 & 0 & m_1 & 0 \\ 0 & 0 & 0 & 0 & 0 & m_1 \end{bmatrix} \quad \mathcal{G}_2 = \begin{bmatrix} 0 & 0 & 0 & 0 & 0 & 0 \\ 0 & 0 & 0 & 0 & 0 & 0 \\ 0 & 0 & 0 & 0 & 0 & 0 \\ 0 & 0 & 0 & m_2 & 0 & 0 \\ 0 & 0 & 0 & 0 & m_2 & 0 \\ 0 & 0 & 0 & 0 & 0 & m_2 \end{bmatrix}.$$

The base is fixed to the ground. It therefore has no velocity. It is however subject to gravity. The gravity vector \mathbf{g} needs to be incorporated in $\dot{\mathcal{V}}_0$. $\mathcal{V}_0 = [0, 0, 0, 0, 0, 0]^T$, $\dot{\mathcal{V}}_0 = [0, 0, 0, 0, 0, g]^T$.

- (b) During the forward iteration of Newton-Euler inverse dynamics, we obtain the states and accelerations of the frames attached to each link. Because the velocity and acceleration of each link is influenced by those of its predecessors, we start our calculations at the base and incrementally move out-board until the states and accelerations for each link have been obtained. As a convention we will express velocities \mathcal{V}_i and accelerations $\dot{\mathcal{V}}_i$ for each link i in the frame $\{i\}$, which is attached to the center of mass of the respective link.

Link 1 states and acceleration:

We now calculate the transformation T_{01} from link 1's predecessor (frame $\{0\}$) to itself (frame $\{1\}$). The equation $T_{01} = \mathcal{M}_1 e^{[\mathcal{A}_1]\theta_1}$ takes \mathcal{M}_1 (the transformation from the base frame $\{0\}$ to the frame $\{1\}$ when the robot is in its home configuration $\theta_1 = \theta_2 = 0$) as a reference point, and incorporates twists (exponential coordinates $\mathcal{A}_1\theta_1$) about joint 1 to find the transformation from frame $\{0\}$ to frame $\{1\}$ for any given θ_1 .

$$T_{01} = \begin{bmatrix} \cos(\theta_1) & -\sin(\theta_1) & 0 & L_1 \cos(\theta_1) \\ \sin(\theta_1) & \cos(\theta_1) & 0 & L_1 \sin(\theta_1) \\ 0 & 0 & 1 & 0 \\ 0 & 0 & 0 & 1 \end{bmatrix}$$

Calculate the absolute velocity \mathcal{V}_1 of the frame $\{1\}$ expressed in frame $\{1\}$.

Detail: \mathcal{V}_1 is composed of two terms: $\mathcal{V}_1 = \text{Ad}_{T_{10}} \mathcal{V}_0 + \mathcal{A}_1 \dot{\theta}_1$.

First term: If joint 1 had a constant angle θ_1 , then the base, together with the first link, could be regarded as a single rigid body. Using the Adjoint of a transformation matrix T_{10} (between two frames $\{1\}$ and $\{0\}$, that are assumed to be fixed to a rigid body), a spacial velocity of one point (ie. frame $\{1\}$) can be expressed in terms of the spacial velocity of another point (ie. frame $\{0\}$). The first term considers the portion of \mathcal{V}_1 , as a result of being attached to a previous dynamic body. In this particular case, the body (base) is stationary, \mathcal{V}_0 is 0 and therefore the first term of the equation is also 0.

Second Term: The joint angle θ_1 of joint 1 is generally not constant and the joint-angle velocity $\dot{\theta}_1$ is not 0. The second term of the equation for \mathcal{V}_1 incorporates the additional velocity of the frame {1} caused by rotating about joint 1. $\mathcal{V}_1 = [0, 0, \dot{\theta}_1, 0, L_1\dot{\theta}_1, 0]^T$.

Calculate the absolute acceleration $\dot{\mathcal{V}}_1$ of the frame {1} expressed in frame {1}.

Detail: $\dot{\mathcal{V}}_1 = \text{Ad}_{T_{10}} \dot{\mathcal{V}}_0 + [\mathcal{V}_1, \mathcal{A}_1]\dot{\theta}_1 + \mathcal{A}_1\ddot{\theta}_1$, where $[\mathcal{V}_1, \mathcal{A}_1]$ indicates the Lie-Bracket operation of \mathcal{V}_1 and \mathcal{A}_1 . The first term considers the acceleration of the previous rigid body, ie. the acceleration of the base frame {0}. The second term considers the coriolis and centripetal accelerations. The third term considers accelerations of frame {1}, due to joint-angle accelerations $\ddot{\theta}_1$.

$$\dot{\mathcal{V}}_1 = [0, 0, \dot{\theta}_1, g \sin(\theta_1), g \cos(\theta_1) + L_1\ddot{\theta}_1, 0]^T.$$

Link 2 states and acceleration:

We now calculate the transformation T_{12} from link {2}'s predecessor (frame {1}) to itself (frame {2}). The equation $T_{12} = \mathcal{M}_{12}e^{[\mathcal{A}_2]\theta_2}$ takes \mathcal{M}_{12} (the transformation from frame {1} to frame {2} when the robot is in its home configuration $\theta_1 = \theta_2 = 0$) as a reference point, and incorporates twists (exponential coordinates $\mathcal{A}_2\theta_2$) about joint 2 to find the transformation from frame {1} to frame {2} for any given θ_2 . $T_{12} =$

$$\begin{bmatrix} \cos(\theta_2) & -\sin(\theta_2) & 0 & L_2 \cos(\theta_2) \\ \sin(\theta_2) & \cos(\theta_2) & 0 & L_2 \sin(\theta_2) \\ 0 & 0 & 1 & 0 \\ 0 & 0 & 0 & 1 \end{bmatrix}$$

Calculate the absolute velocity \mathcal{V}_2 of the frame {2} expressed in frame {2}.

Detail: \mathcal{V}_2 is composed of two terms: $\mathcal{V}_2 = \text{Ad}_{T_{21}} \mathcal{V}_1 + \mathcal{A}_2\dot{\theta}_2$.

First term: If joint 2 had a constant angle θ_2 , then link 1, together with link 2, could be regarded as a single rigid body. Using the Adjoint of a transformation matrix T_{21} (between two frames {2} and {1}, that are assumed to be fixed to a rigid body) a spacial velocity of one point (ie. frame {2}) can be expressed in terms of the spacial velocity of another point (ie. frame {1}). The first term considers the portion of \mathcal{V}_2 , as a result of being attached to a previous dynamic body.

Second Term: The joint angle θ_2 of joint 2 is generally not constant and the joint-angle velocity $\dot{\theta}_2$ is not 0. The second term of the equation for \mathcal{V}_2 incorporates the additional velocity of the frame {2} caused by rotating about joint 2.

$$\mathcal{V}_2 = [0, 0, \dot{\theta}_1 + \dot{\theta}_2, L_1 \sin(\theta_2) \dot{\theta}_1, (L_2 + L_1 \cos(\theta_2)) \dot{\theta}_1 + L_2 \dot{\theta}_2, 0]^T.$$

Calculate the absolute acceleration $\dot{\mathcal{V}}_2$ of the frame $\{2\}$ expressed in frame $\{2\}$:

Detail: $\dot{\mathcal{V}}_2 = \text{Ad}_{T_{21}} \dot{\mathcal{V}}_1 + [\mathcal{V}_2, \mathcal{A}_2] \dot{\theta}_2 + \mathcal{A}_2 \ddot{\theta}_2$, where $[\mathcal{V}_2, \mathcal{A}_2]$ indicates the Lie-Bracket operation of \mathcal{V}_2 and \mathcal{A}_2 . The first term considers the acceleration of the previous rigid body, ie. the acceleration of the base frame $\{1\}$. The second term considers the coriolis and centripetal accelerations. The third term considers accelerations of frame $\{2\}$, due to joint-angle accelerations $\ddot{\theta}_2$.

$$\dot{\mathcal{V}}_2 = [0, 0, \ddot{\theta}_1 + \ddot{\theta}_2, g \sin(\theta_1 + \theta_2) + L_1 \cos(\theta_2) \dot{\theta}_1 \dot{\theta}_2 + L_1 \sin(\theta_2) \ddot{\theta}_1, g \cos(\theta_1 + \theta_2) - L_1 \sin(\theta_2) \dot{\theta}_1 \dot{\theta}_2 + (L_2 + L_1 \cos(\theta_2)) \ddot{\theta}_1 + L_2 \ddot{\theta}_2]^T.$$

- (c) During the forward iteration, we had to bear in mind that the velocity and acceleration of link i is dependent on those of its predecessor link $i - 1$. Similarly, the forces acting on a link i are dependent on the forces acting on its outboard follower ($i + 1$): The wrench \mathcal{F}_i that must be applied to link i is the sum of the wrench \mathcal{F}_{i+1} that must be provided to link $i + 1$ (but expressed in frame $\{i\}$) plus the extra wrench from the rigid body dynamics of link i . In other words, the inboard links need to support the outboard links. For that reason, we run a backward iteration starting with the most outboard link and incrementally approach the base link. Ultimately, we are solving for the torques acting on each joint, to obtain the control torques that need to be provided to the joint motors.

Link 2 forces and torques: Find the transform from frame $\{2\}$ to frame $\{3\}$. The frame $n + 1$ (in this case 3) is the frame attached to the end-effector. For the 2R arm we assumed that the frame $\{3\}$ coincides with frame $\{2\}$ (both the center of mass of link 2, as well as the end-effector are located at the tip of link 2). We therefore know, that T_{23} is the identity transformation in $SE(3)$,

$$T_{23} = \text{diag}(1, 1, 1, 1).$$

\mathcal{F}_3 is the wrench that the end-effector applies to the environment expressed in the frame $\{3\}$. It is given as 0.

$$\mathcal{F}_{\text{tip}} = \mathcal{F}_3 = [0, 0, 0, 0, 0, 0]^T.$$

Calculate \mathcal{F}_2 using the equation $\mathcal{F}_2 = \text{Ad}_{T_{32}} \mathcal{F}_{\text{tip}} + \mathcal{G}_2 \dot{\mathcal{V}}_2 - \text{ad}_{\mathcal{V}_2}^T(\mathcal{G}_2 \mathcal{V}_2)$.

Details: The first term is the wrench that must be provided by the end-effector (expressed in frame $\{2\}$). The second and third terms are the wrench that results from the dynamics of link 2.

$$\mathcal{F}_2 = [0, 0, 0, m_2(g \sin(\theta_1 + \theta_2) - L_1 \cos(\theta_2) \dot{\theta}_1^2 - L_2(\dot{\theta}_1 + \dot{\theta}_2)^2 + L_1 \sin(\theta_2) \ddot{\theta}_1), m_2(g \cos(\theta_1 + \theta_2) + L_1 \sin(\theta_2) \dot{\theta}_1^2 + (L_2 + L_1 \cos(\theta_2)) \ddot{\theta}_1 + L_2 \ddot{\theta}_2), 0]^T.$$

To obtain the torque acting on joint 2, the wrench \mathcal{F}_2 is multiplied with the twist-vector for joint 2 expressed in the frame 2, namely \mathcal{A}_2 ,

$$\tau_2 = L_2 m_2 (\ddot{\theta}_2 L_2 + \dot{\theta}_1 (L_2 + L_1 \cos(\theta_2)) + g \cos(\theta_1 + \theta_2) + \dot{\theta}_1^2 L_1 \sin(\theta_2)).$$

Link 1 forces and torques are obtained analogous to link 2: $\mathcal{F}_1 = [0, 0, L_2 m_2 (L_1 \sin(\theta_2) \dot{\theta}_1^2 + \ddot{\theta}_2 L_2 + \dot{\theta}_1 (L_2 + L_1 \cos(\theta_2)) + g \cos(\theta_1 + \theta_2)), -L_2 m_2 \cos(\theta_2) (\dot{\theta}_1 + \dot{\theta}_2)^2 + (m_1 + m_2)(g \sin(\theta_1) - \dot{\theta}_1^2 L_1) - (\dot{\theta}_1 + \dot{\theta}_2) L_2 m_2 \sin(\theta_2), -L_2 m_2 \sin(\theta_2) (\dot{\theta}_1 + \dot{\theta}_2)^2 + (m_1 + m_2)(\dot{\theta}_1 L_1 + g \cos(\theta_1)) + (\dot{\theta}_1 + \dot{\theta}_2) L_2 m_2 \cos(\theta_2), 0]^T$.

$$\tau_1 = g L_1 (m_1 + m_2) \cos(\theta_1) + \dot{\theta}_2 L_2 m_2 (L_2 + L_1 \cos(\theta_2)) + \dot{\theta}_1 (L_2^2 m_2 + L_1^2 (m_1 + m_2) + 2 L_1 L_2 m_2 \cos(\theta_2)) + g L_2 m_2 \cos(\theta_1 + \theta_2) - 2 \dot{\theta}_1 \dot{\theta}_2 L_1 L_2 m_2 \sin(\theta_2) - \dot{\theta}_2^2 L_1 L_2 m_2 \sin(\theta_2)$$

The outputs τ_1 and τ_2 are consistent with the results from the lagrangian approach! We have therefore successfully demonstrated the Newton-Euler inverse dynamics derivation for the 2R arm.

Chapter 9

Practice Exercises on Trajectory Generation

9.1 Practice Exercises

Practice exercise 9.1 Consider generating trajectories for the 7R WAM robot, whose kinematics are given in Section 4.1.3 of the textbook. The start and end configurations of the end-effector are

$$X_{\text{start}} = \begin{bmatrix} \sqrt{2}/2 & 0 & \sqrt{2}/2 & -0.2 \\ -\sqrt{2}/2 & 0 & \sqrt{2}/2 & 0.1 \\ 0 & -1 & 0 & 0.4 \\ 0 & 0 & 0 & 1 \end{bmatrix}$$

and

$$X_{\text{end}} = \begin{bmatrix} -\sqrt{2}/2 & 0 & \sqrt{2}/2 & -0.2 \\ -\sqrt{2}/2 & 0 & -\sqrt{2}/2 & -0.1 \\ 0 & -1 & 0 & 0.4 \\ 0 & 0 & 0 & 1 \end{bmatrix}.$$

We will generate 11 transformation matrices along each trajectory using a cubic time scaling with a total motion time of 5 seconds. You can ignore all the joint limits in this exercise.

- (a) Use the function `CartesianTrajectory` in the MR library to generate the trajectory. Plot the (x, y, z) components, and the three exponential

coordinates of rotation, of the transformation matrices as a function of time.

- (b) Use the function `ScrewTrajectory` in the MR library to generate the trajectory. Plot the (x, y, z) components, and the three exponential coordinates of rotation, of the transformation matrices as a function of time.
- (c) Using a good initial guess at the joint angles for the first configuration along the trajectories, use `IKinBody` (and the solution from the previous configuration) to find appropriate joint angles at each frame along the trajectories. Are both trajectories feasible?

Practice exercise 9.2 Consider a robot executing a motion of duration $T = 2$ s. Initially the robot follows a cubic time scaling. At $t = 1$ s, however, it switches to a quintic time scaling. This quintic time scaling, beginning at $t = 1$ s, should match the position, velocity, and acceleration of the cubic time scaling which is ending at that time, i.e., $s(1) = 1/2$, $\dot{s}(1) = 3/4$, and $\ddot{s}(1) = 0$. Solve for the complete time scaling $s(t) : [0, 2] \rightarrow [0, 1]$. You should set up a set of linear equations for the coefficients during the quintic time scaling, which you could solve using the `\` operator in MATLAB, `LinearSolve` in Mathematica, or `scipy.linalg.solve` in Python.

Practice exercise 9.3 Figure 9.1 shows four proposed time scalings in the (s, \dot{s}) -plane (part of the curve (b) coincides with the velocity limit curve). Indicate which proposed time scalings are guaranteed to be infeasible (without knowing anything more about the dynamics) and explain your reasoning. Explain the differences between the feasible time scalings and time-optimal time scalings.

Practice exercise 9.4 Time-optimal time scaling requires step changes in acceleration (“bang-bang” motions), and therefore infinite jerk. An example time-optimal time scaling is shown in Figure 9.2. How might you modify this time scaling if you would like to enforce bounded jerk? Sketch the new time scaling.

Practice exercise 9.5 A time scaling can be written as either $s(t)$ or $\dot{s}(s)$. The first segment of a trapezoidal time scaling is $s(t) = (1/2)at^2$. Write this segment as $\dot{s}(s)$. In other words, eliminate t from the expression.

Practice exercise 9.6 The dynamics of a two-joint robot restricted to a path $\theta(s)$ are $m(s)\ddot{s} + c(s)\dot{s}^2 + g(s) = \tau$. At the state $(s, \dot{s}) = (0.5, 2)$, the vectors

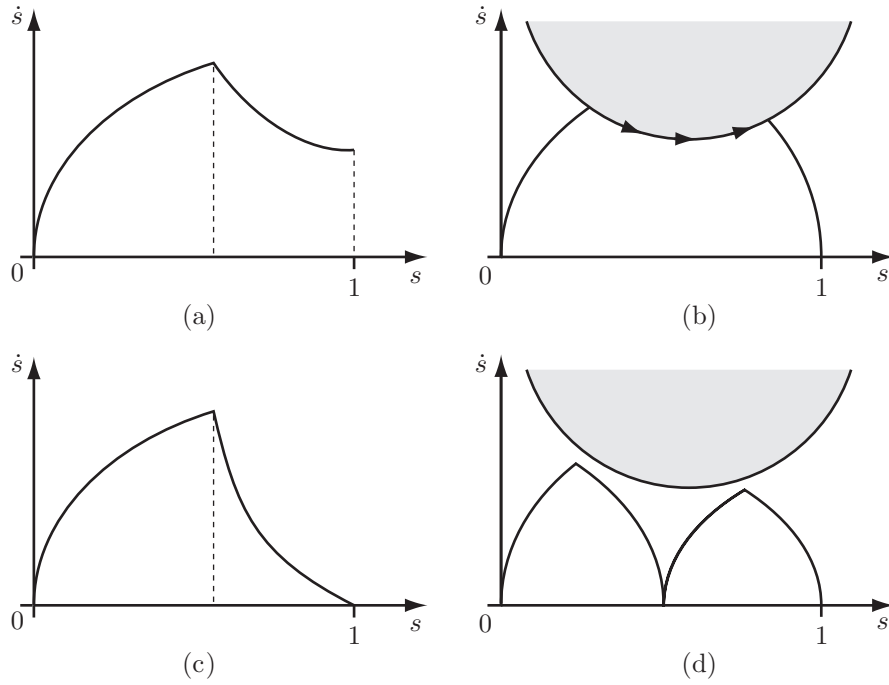

Figure 9.1: 4 candidate motion curves

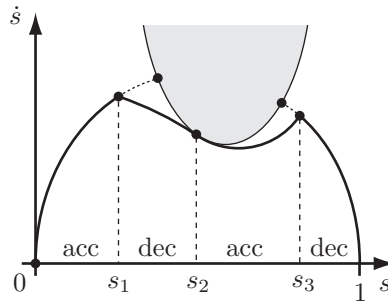

Figure 9.2: A typical time-optimal time scaling.

$m(s)$, $c(s)$, and $g(s)$ evaluate to

$$m(0.5) = \begin{bmatrix} 1 \\ -1 \end{bmatrix}, \quad c(0.5) = \begin{bmatrix} 3 \\ -3 \end{bmatrix}, \quad g(0.5) = \begin{bmatrix} 0 \\ 5 \end{bmatrix}.$$

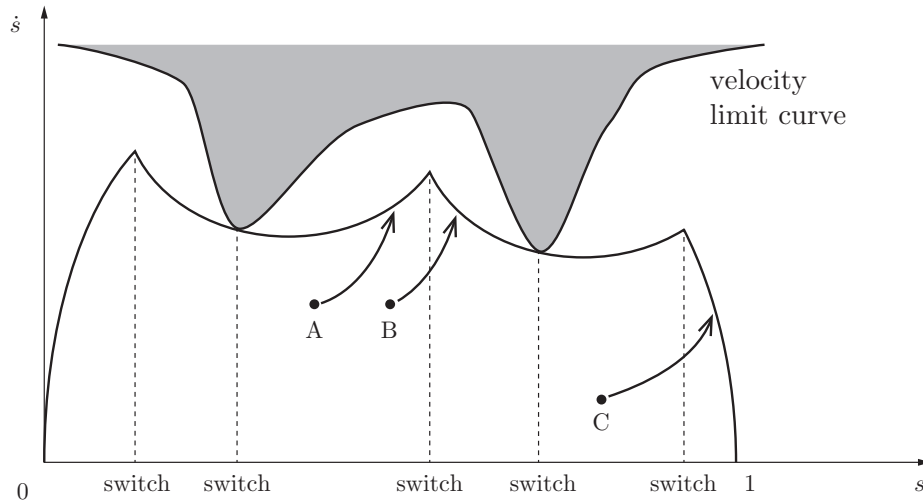

Figure 9.3: A time-optimal time scaling.

At this state (s, \dot{s}) , each actuator is limited in the torque it can apply to $-10 \leq \tau_i \leq 10$.

- At this state (s, \dot{s}) , give the lower and upper bounds on the feasible accelerations \ddot{s} due to joint 1 (L_1 and U_1) and joint 2 (L_2 and U_2).
- Can the robot stay on the path at this state? Explain your answer. If your answer is yes, indicate the range of feasible accelerations \ddot{s} and clearly draw the motion cone in the (s, \dot{s}) plane.

Practice exercise 9.7 Ignore the points A, B, and C, and the arrows emanating from them, until part (c) of the problem.

- For the time-optimal time scaling in Figure 9.3, approximately draw the feasible motion cone at every point on the curve where we know the angle of both the upper and lower bounds of the cone. (Assume the robot can hold itself stationary at any configuration $s \in [0, 1]$.)
- Draw a point in the (s, \dot{s}) plane from which the robot can stay on the path for a little while longer, but from which the robot is doomed to eventually leave the path. Label this point “b” so it is easy to see.
- Suppose the robot finds itself at the states A, B, or C, off of the time-optimal time scaling. The time-optimal time scalings from these states

involve the robot getting back to the scaling curve shown. To get back to the time-optimal time scaling, the robot attempts to follow the trajectories indicated by the arrows. Without knowing anything more about the robot's dynamics, can we say with certainty that any of these "arrow" trajectories is impossible? If so, which? Explain your answer.

9.2 Solutions

Solution 9.1

- (a) The (x, y, z) components, and the three exponential coordinates of rotation, of the Cartesian trajectory are plotted below.

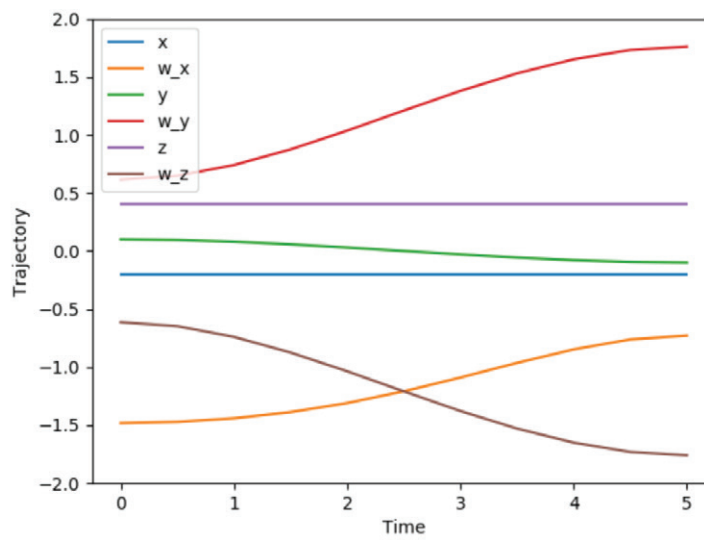

- (b) The (x, y, z) components, and the three exponential coordinates of rotation, of the screw trajectory are plotted below.

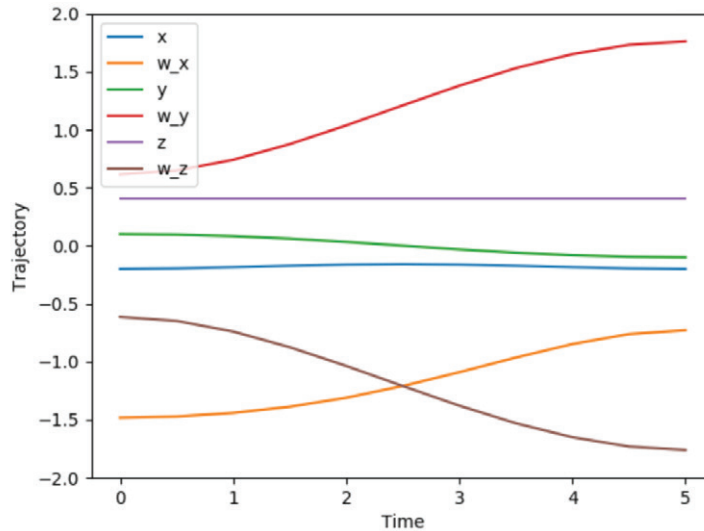

- (c) The screw trajectory leaves the workspace, so is not feasible. The function `ScrewTrajectory` returns one possible screw trajectory, where the angle traveled is less than π . It is possible to find a screw trajectory of the opposite rotation sense (and a screw angle greater than π) that remains within the workspace.

Solution 9.2 For $t \in [0, 1]$, the time scaling is the same with a cubic time scaling. For $t \in [1, 2]$, the quintic time scaling, $s(t) = a_0 + \dots + a_5 t^5$ can be calculated by solving a system of linear equations based on the constraints at $t = 1$ and $t = 2$, i.e.,

$$\begin{bmatrix} 1 & 1 & 1 & 1 & 1 & 1 \\ 1 & 2 & 4 & 8 & 16 & 32 \\ 0 & 1 & 2 & 3 & 4 & 5 \\ 0 & 1 & 4 & 12 & 32 & 80 \\ 0 & 0 & 2 & 6 & 12 & 20 \\ 0 & 0 & 2 & 12 & 48 & 160 \end{bmatrix} \begin{bmatrix} a_0 \\ a_1 \\ a_2 \\ a_3 \\ a_4 \\ a_5 \end{bmatrix} = \begin{bmatrix} 1/2 \\ 1 \\ 3/4 \\ 0 \\ 0 \\ 0 \end{bmatrix}.$$

Solving, we get

$$s(t) = \begin{cases} \frac{3}{4}t^2 - \frac{1}{4}t^3 & t \in [0, 1) \\ -3 + 12t - 18t^2 + 14t^3 - \frac{21}{4}t^4 + \frac{3}{4}t^5 & t \in [1, 2]. \end{cases}$$

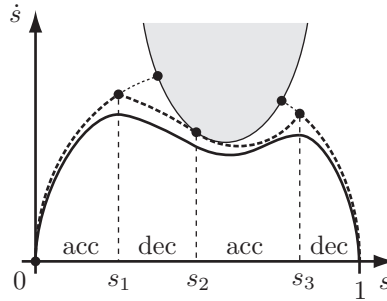

Figure 9.4: A bounded-jerk time scaling.

Solution 9.3 Time scalings (b) and (c) are infeasible. (b) At points on the velocity limit curve, the feasible motion cone reduces to a single tangent vector. A feasible time scaling can only touch the limit curve at points where the time scaling is tangent to the limit curve. But at the point where the time scaling initially contacts the velocity limit curve, and at the point that it departs the limit curve, the time scaling has a tangent that is not also tangent to the velocity limit curve. (c) At all points where $\dot{s} = 0$, the tangent to the time scaling must be vertical.

In (a), the time scaling does not achieve $\dot{s} = 0$ at $s = 1$. In (b), the time scaling is feasible but not time optimal, since a time-optimal time scaling should either have only one switch or it should contact the velocity limit curve.

Solution 9.4 Figure 9.4 shows one possible solution. Basically, the “corners” at the first and last switch have to be “rounded” to avoid discontinuous acceleration. In this drawing, the new time scaling never touches the velocity limit curve, but one could imagine a bounded jerk time scaling that still touches the velocity limit curve. In any case, the new time scaling can never be “above” the time-optimal time scaling in the \dot{s} direction.

Solution 9.5 $t = \sqrt{2s/a}$ and $\dot{s} = at$, so $\dot{s}(s) = \sqrt{2as}$.

Solution 9.6

- (a) Joint 1: $-10 \leq \ddot{s} + 12 \leq 10 \rightarrow L_1 = -22, U_1 = -2$. Joint 2: $-10 \leq -\ddot{s} - 3(4) + 5 \leq 10 \rightarrow L_2 = -17, U_2 = 3$.
- (b) $L = \max(L_1, L_2) = -17, U = \min(U_1, U_2) = -2$. We have $U > L$, so it

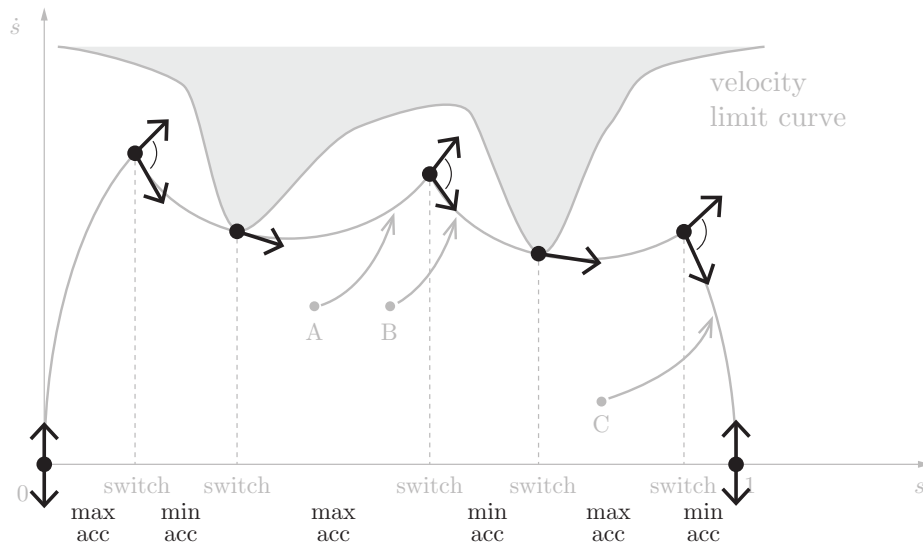
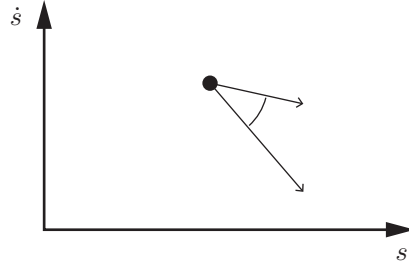

Figure 9.5: Points where the motion cone is known, and intervals of the s -axis labeled as “max acc,” where the time-optimal time scaling follows the maximum possible acceleration along the path) and “min acc,” where the time scaling follows the minimum acceleration (sometimes called maximum deceleration).

is possible to stay on the path, with $\ddot{s} \in [-17, -2]$. The motion cone is illustrated below:



Solution 9.7

- We know the angles of the upper and lower bounds of the motion cone at the seven points indicated in Figure 9.5.
- Any trajectory beginning from a point between the top of the optimal time scaling and below the velocity limit curve, and in an s -range for minimum

acceleration for the time-optimal time scaling, will eventually reach the velocity limit curve. Even with minimum acceleration, the robot cannot get back down to the time scaling curve before hitting the limit curve or passing $s = 1$.

- (c) The trajectory from A is impossible. It is fully in an s -range marked “maximum acceleration” for the optimal time scaling, so there is no way for the robot to catch up to a robot already moving at a higher speed.

Chapter 10

Practice Exercises on Motion Planning

10.1 Practice Exercises

10.2 Solutions

Chapter 11

Practice Exercises on Robot Control

11.1 Practice Exercises

Practice exercise 11.1 The second-order error dynamics of systems A , B , C , D , and E can all be expressed as

$$m\ddot{\theta}_e + b\dot{\theta}_e + k\theta_e = 0.$$

Considered as a mass-spring-damper system, m is the effective mass, b is the effective damping constant, and k is the effective spring constant. The five systems share the same m , but their damping constants b and spring constants k are different. Figure 11.1 shows one of the complex conjugate roots of the characteristic equation $ms^2 + bs + k = 0$ for each of the five systems. The roots of A , B and C are on a circle with its center at the origin, while the roots of D , E are on a line passing through the origin.

- Give the natural frequency ω_n and damping ratio ζ of the error dynamics above.
- List these five systems in order of their natural frequency, from the highest to the lowest (group together any that are equal).
- List these five systems in order of their damped natural frequency, from the highest to the lowest (group together any that are equal).
- List these five systems in order of their damping ratio, from the highest to the lowest (group together any that are equal).

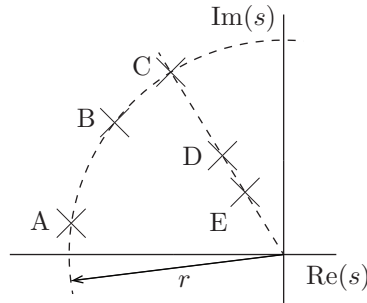

Figure 11.1: Roots in the s -plane.

- (e) List these five systems in order of their overshoot to a step input, from the largest to the smallest (group together any that are equal).
- (f) List these five systems in order of their settling time, from the longest to the shortest (group together any that are equal).
- (g) Which system has the “best” transient error response?
- (h) To make the dynamics of A the same as C , how should you change the damping constant b_A and spring constant k_A ? If both b_A and k_A should be changed, indicate any conditions b_A and k_A must satisfy.
- (i) To make the dynamics of E the same as C , how should you change the damping constant b_E and spring constant k_E ? If both b_E and k_E should be changed, indicate any conditions b_E and k_E must satisfy.

Practice exercise 11.2 An example error response plot is shown in Figure 11.2.

- (a) Give the steady-state error e_{ss} and the overshoot (as a percentage).
- (b) Draw an error response for a controller with better performance.

Practice exercise 11.3 Consider the error dynamics

$$\theta_e^{(5)} + 2\theta_e^{(4)} + \theta_e^{(3)} + 2\ddot{\theta}_e + 4\dot{\theta}_e + 2\theta = 0$$

Is it homogeneous or nonhomogeneous? Verify whether it is stable or not.

Practice exercise 11.4 Write a program to approximately recreate the plots of Figure 11.8 of the textbook, showing the response of a P and PI controller. Your controller commands the joint velocity $\dot{\theta}$, the desired motion is $\theta_d(t) = t$,

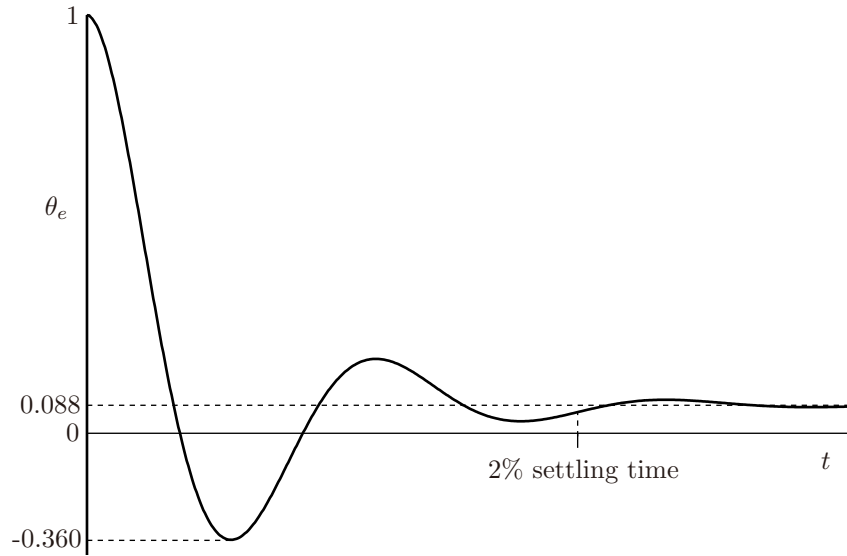

Figure 11.2: An example error response.

and the initial condition is $\theta(0) = 0.2$ (i.e., $\theta_e(0) = \theta_d(0) - \theta(0) = -0.2$).

Practice exercise 11.5 You will design a computed-torque controller for an n -joint robot with the dynamics

$$\tau = M(\theta)\ddot{\theta} + c(\theta, \dot{\theta}) + g(\theta).$$

Of course you do not know the robot's dynamics exactly; your model is

$$\tau = \tilde{M}(\theta)\ddot{\theta} + \tilde{c}(\theta, \dot{\theta}) + \tilde{g}(\theta),$$

where hopefully $\{\tilde{M}, \tilde{c}, \tilde{g}\}$ is “close” to $\{M, c, g\}$. (Except for the last part of the problem, assume $\{\tilde{M}, \tilde{c}, \tilde{g}\} = \{M, c, g\}$.)

- (a) Your computed-torque design will be based on PID feedback. Let $\ddot{\theta}_c(t)$ be the controller's commanded joint accelerations at time t ,

$$\ddot{\theta}_c(t) = \ddot{\theta}_{ff}(t) + \ddot{\theta}_{fb}(t),$$

where the feedforward acceleration $\ddot{\theta}_{ff}(t)$ from the planned trajectory is $\ddot{\theta}_d(t)$ and the feedback acceleration from the feedback controller is

$$\ddot{\theta}_{fb}(t) = K_p \theta_e(t) + K_i \int_0^t \theta_e(t) dt + K_d \dot{\theta}_e(t).$$

Write the full computed-torque controller $\tau(t) = \dots$ (include the dependence on time).

- (b) The actual joint acceleration at time t is

$$\ddot{\theta}(t) = \ddot{\theta}_c(t) + \ddot{\theta}_{\text{dist}}(t),$$

where $\ddot{\theta}_{\text{dist}}(t)$ is a disturbance acceleration, perhaps due to unmodeled forces. With this, the total joint acceleration is

$$\ddot{\theta}(t) = \ddot{\theta}_d(t) + K_p \theta_e(t) + K_i \int_0^t \theta_e(t) dt + K_d \dot{\theta}_e(t) + \ddot{\theta}_{\text{dist}}(t).$$

Given that $\theta_e = \theta_d - \theta$, write the error dynamics differential equation.

- (c) Set $K_i = 0$ (your computed-torque controller does not use integral feedback) and $\ddot{\theta}_{\text{dist}} = 0$ and write the error dynamics. What conditions must K_p and K_d satisfy to ensure stability of the error dynamics? Choose the gain matrices K_p and K_d so that the error dynamics at each joint are critically damped with a settling time of 0.1 s. Comment on the steady-state error. What problems might occur if you choose the settling time to be unrealistically short?
- (d) Set $K_i = 0$ and $\ddot{\theta}_{\text{dist}}(t) = c$, a constant vector. Write the error dynamics. If K_p and K_d are chosen to make the error dynamics stable, what is the steady-state error?
- (e) Now you will choose $K_i > 0$ and $\ddot{\theta}_{\text{dist}} = c$. Write the error dynamics. If you keep the same gains K_p and K_d as in part (c), and choose K_i to be positive but very small (nearly zero), where are the three roots of the characteristic equation of the error dynamics in the s -plane? As you increase K_i , eventually two of the roots will be coincident on the real axis and there will be one more root further to the left on the real axis. For what value of K_i will this occur, and where are the roots? (You could use a symbolic math package, like Mathematica, to help you with this.) If you increase K_i further, eventually the system will become unstable. For what value of K_i will this occur, and where are the roots? (Again, a symbolic math package would be helpful.) Approximately plot by hand, or use a computer to plot, the motion of the roots as you increase K_i from zero to the point where the system becomes unstable. For all choices of K_i that keep the system stable, what is the steady-state error? Provide a reason or two why many real-world robot controllers do not use an integral term.
- (f) Now assume that your dynamic model of the robot is not very accurate (e.g., the inertias of the links are not well known), but your static model of the robot is good (e.g., the masses and locations of the centers of mass

of the links are well characterized). Also assume that your control goals are more modest: you will only ask the robot to track slow trajectories. What might be a good alternative control law that takes advantage of your static model of the robot but does not use the dynamic model?

11.2 Solutions

Solution 11.1

- (a) $\omega_n = \sqrt{k/m}$, $\zeta = b/(2\sqrt{km})$.
- (b) As shown in Figure 11.5 (top right) of the textbook, the distance between the root and the origin is the natural frequency. Therefore, from highest natural frequency to lowest, we have $(A, B, C), D, E$.
- (c) The damped natural frequency is determined by the imaginary portion of the roots, so from highest damped natural frequency to lowest, we have C, B, D, E, A .
- (d) The damping ratio can be expressed as

$$\zeta = \cos \alpha$$

where α is the angle from the negative x -axis to the line connecting the origin to the root. Therefore, from highest damping ratio to lowest, we have $A, B, (C, D, E)$.

- (e) The overshoot is inversely related to the damping ratio, so from largest overshoot to smallest, we have $(C, D, E), B, A$.
- (f) The settling time is longer as the roots move toward the imaginary axis (and the system becomes unstable if they pass into the right-half plane), so from longest settling time to shortest, we have E, D, C, B, A .
- (g) System A has the fastest settling time and least overshoot.
- (h) Systems A and C already have the same natural frequency, so k_A should not be changed. To get the same damping ratio, b_A should be decreased.
- (i) Systems E and C have the same damping ratio but E has a smaller natural frequency than C . So k_E must be increased to achieve C 's natural frequency, and b_E must be increased so that the damping ratio is unchanged.

Solution 11.2

- (a) $e_{ss} = 0.88$,
overshoot = $|\frac{-0.360-0.088}{1-0.088}| \times 100\% = 49.123\%$.
- (b) Any reasonable drawing is fine. An example better error response, with smaller steady-state error, less overshoot, and a faster settling time, is shown in Figure 11.3.

Solution 11.3 The error dynamics are homogeneous. To check stability, we can write the characteristic equation

$$s^5 + 2s^4 + s^3 + 2s^2 + 4s + 2 = 0.$$

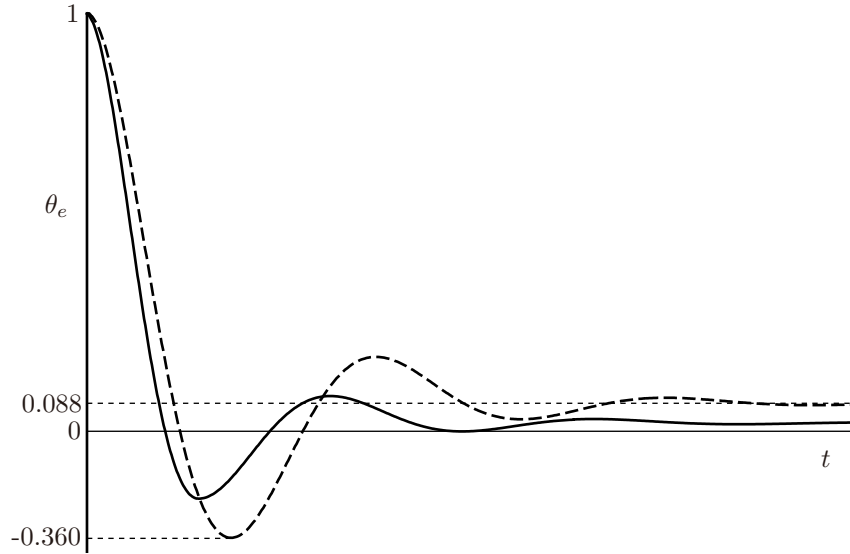

Figure 11.3: A plot of a better error response.

The roots must all have a negative real component. You could calculate the roots using symbolic math software, or

$$\begin{aligned} s^5 + 2s^4 + s^3 + 2s^2 + 4s + 2 &= 0 \\ s^3(s+1)^2 + 2(s+1)^2 &= 0 \\ (s^3 + 2)(s+1)^2 &= 0. \end{aligned}$$

The roots are -1 , -1 , $-\sqrt{2}$, and $0.63 \pm 1.09j$. Because the last two roots have a positive real component, the error dynamics are unstable.

Solution 11.4 The P control error dynamics is a first-order nonhomogeneous linear equation with the solution

$$\theta_e(t) = \frac{c}{K_p} + \left(\theta_e(0) - \frac{c}{K_p} \right) e^{-K_p t}$$

as given in the textbook, where in this case $c = \dot{\theta}_d(t) = 1$ from the original figure. The PI control error dynamics is a second-order homogeneous linear equation with the solution

$$\theta_e(t) = (c_1 \cos \omega_d t + c_2 \sin \omega_d t) e^{-\zeta \omega_n t}$$

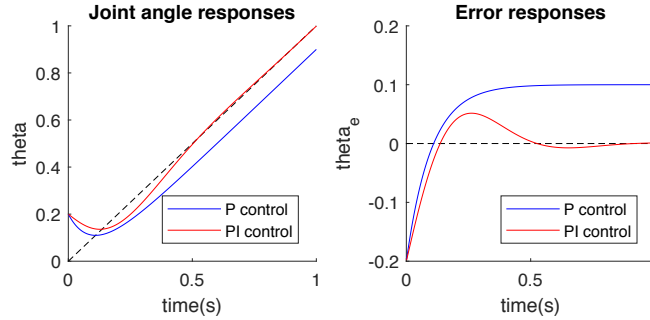

Figure 11.4: An example solution.

as given in the textbook, where $\omega_d = \omega_n \sqrt{1 - \zeta^2}$, $\omega_n = \sqrt{K_i}$ and $\zeta = K_p / (2\sqrt{K_i})$. c_1 and c_2 can be calculated from initial conditions. An example is shown in Figure 11.4.

Solution 11.5

(a)

$$\begin{aligned} \tau(t) = & \tilde{M}(\theta(t)) \left(\ddot{\theta}_d(t) + K_p \theta_e(t) + K_i \int_0^t \theta_e(t) dt + K_d \dot{\theta}_e(t) \right) \\ & + \tilde{c}(\theta(t), \dot{\theta}(t)) + \tilde{g}(\theta(t)). \end{aligned}$$

(b)

$$\ddot{\theta}_e + K_d \dot{\theta}_e + K_p \theta_e + K_i \int \theta_e dt = -\ddot{\theta}_{\text{dist}}. \quad (11.1)$$

(c) $K_i = 0$ and $\ddot{\theta}_{\text{dist}} = 0$, so Equation (11.1) becomes

$$\ddot{\theta}_e + K_d \dot{\theta}_e + K_p \theta_e = 0.$$

A necessary and sufficient condition for stability for the second-order error dynamics is that both K_d and K_p are positive definite (for example, each could be a diagonal matrix with identical positive entries on the diagonal). For the error dynamics to be critically damped with a 2% settling time of $4t = 0.1$ s for a given joint, both roots must be at $s = -1/t = -40$. So we need

$$(s + 40)^2 = s^2 + k_d s + k_p,$$

where k_d and k_p are scalars. Expanding, we get $k_d = 80$ and $k_p = 1600$. The matrices K_d and K_p are diagonal matrices with k_d and k_p on the

diagonals, respectively. The steady-state error is zero because the stable error dynamics are homogeneous. If we choose the settling time to be very short, the roots move far to the left in the s -plane, the required gains will become large, and the system may no longer be linear due to the actuators saturating (e.g., the actuators may operate at their limits in response to small errors).

- (d) The error dynamics (11.1) now become $\ddot{\theta}_e + K_d\dot{\theta}_e + K_p\theta_e = -c$. The steady-state error for each joint for stable dynamics is $\theta_e = -c/k_p$ if K_p is a diagonal matrix with k_p on the diagonal. The steady-state error can be made small by choosing k_p large, but it cannot be made zero.
- (e) Taking the derivative of the error dynamics (11.1), we get

$$\theta_e^{(3)} + K_d\ddot{\theta}_e + K_p\dot{\theta}_e + K_i\theta_e = 0.$$

Considering a single joint, if $k_i > 0$ is very small, and $k_d = 80$ and $k_p = 1600$ as calculated earlier, then the characteristic equation of the error dynamics is approximately

$$(s + 40)^2(s + \epsilon)^2 = 0,$$

and there are two roots at -40 and one at $-\epsilon$, where $\epsilon > 0$ is very small. As we increase k_i , eventually two roots are coincident on the real axis with one further to the left. We can write

$$(s + a)^2(s + b) = s^3 + (2a + b)s^2 + (2ab + a^2)s + a^2b = s^3 + 80s^2 + 1600s + k_i$$

and solve

$$\begin{aligned} 2a + b &= 80 \\ 2ab + a^2 &= 1600 \\ a^2b &= k_i \end{aligned}$$

for a , b , and k_i . Using symbolic math software, we get

$$a = 13.33, b = 53.33, k_i = 9481.48,$$

so there are two roots at -13.33 and one root at -53.33 for a gain $k_i = 9481.48$.

As we increase k_i further, eventually two roots are on the imaginary axis, and we have

$$(s + a)(s + bj)(s - bj) = s^3 + as^2 + b^2s + ab^2 = s^3 + 80s^2 + 1600s + k_i,$$

and solving we get $a = 80$, $b = 40$, and $k_i = 128,000$. So for this k_i , there are roots at -80 and $\pm 40j$.

Since the error dynamics are homogeneous, for all choices of k_i that keep the roots in the left-half plane, the steady-state error is zero. However, many robot controllers avoid integral control because PD feedback terms suffice for small steady-state error, and integral terms can worsen the transient response or possibly even lead to instability, which would be disastrous.

- (f) A good controller might be a PD controller plus gravity compensation (similar to Equation (11.38) in Chapter 11.4.2.2, but without the potentially destabilizing integral term).